

Safety Grating

GSSG-13R

GRIP STRUT™

safety grating

Exclusively Distributed By: MARCO Specialty Steel, Inc.



MARCO
SPECIALTY STEEL

Marco Specialty Steel, Inc.
9140 Tavenor Lane
Houston, Texas 77075

Phone: 713-649-5310,
800-200-3047

Fax: 713-649-5305

www.marcospecialtysteel.com

Table of Contents & Advantages

Advantages	2
Proof Of Performance	3
General Load Information	4-5
Design Load Tables (Steel, Aluminum, Stainless Steel)	
2-Diamond Planks - 4 ³ / ₄ " Width	6-7
3-Diamond Planks - 7" Width	8-9
4-Diamond Planks - 9 ¹ / ₂ " Width	10-11
5-Diamond Planks - 11 ³ / ₄ " Width	12-13
8-Diamond Planks - 18 ³ / ₄ " Width	14-15
10-Diamond Planks - 24" Width	16
10-Diamond Walkway - 24" Width	17
Comparative Performance Tables	18-19
Accessories	20-23
Specials & Fabricated Products	24-25
Stair Treads	26-27
Specifications	28-29
How To Order	30
Installation Recommendations	31

Safer, serrated surface

Grips soles securely in all directions. The non-slip GRIP STRUT surface is ideal for inside or outside locations where mud, ice, snow, oil and detergents can create hazardous walking conditions. Openings are small enough to catch most falling tools and other dangerous objects.

Open design, convenient cleaning

Permits quick drainage of fluids, chips, grease and mud. Any ice accumulation shears easily under normal foot pressure. Open design allows convenient access for cleaning, and is easily cleaned with brush, liquid or air spray to help minimize overall maintenance.

High load capacity, long life

High strength-to-weight performance is achieved through depth of section and structural design. Bridged struts with integral side channels form a plank that can support loads with minimum transverse and longitudinal deflection. There are no rivets or pressure joints to break or loosen. This sturdy construction provides the advantages of heavy load-carrying capacity with minimal deflection; rugged durability with longer-lasting performance.

Fast Installation

Light, easy-to-handle planks make installation simpler and quicker. They can be handled by one man. Most sections are rapidly bolted, clamped or welded into place, easily field-cut at virtually any angle, or fabricated to adapt to field conditions. Several attachment devices permit fastening to most existing surfaces; allow fast installation or disassembly.

Economical to install, use

In addition to low material cost and nominal erection cost, GRIP STRUT™ safety grating also helps save with its long-lasting, rust-resisting materials and finishes. Standard mill-galvanized finish resists corrosion to provide lasting surfaces. High-strength aluminum and Types 304 and 316L stainless steel are available to provide maximum corrosion resistance. Black unpainted steel available for installations requiring hot dipped galvanized finish after fabrication. These light weight but brawny panels permit substantial reduction in structural steel requirements. Open design is self-cleaning and virtually maintenance free.

Versatile in application

A variety of standard widths and channel heights combine with numerous non-standard shapes and sizes to meet almost any requirement of strength, size, durability, weight, finish, appearance and application. GRIP STRUT safety grating combines safety and durability with ease of fabrication and versatility. One piece construction with no welds or rivets to fail, minimizes need for plant fabrication. Special shapes and forming can be accomplished to suit unusual requirements.



Close-up of standard pattern



Standard serrated surface



Non-serrated surface also available

Tested by an independent laboratory for slip resistance according to standards and methods established by Federal Specifications RR-G-1602D, GRIP STRUT™ safety grating exceeds all requirements of this specification.

- The standards were exacting - five shoe sole materials tested in three directions under five conditions: dry, greasy, muddy, soapy and icy. GRIP STRUT safety grating tested more slip-resistant than similar materials, depending on shoe materials and surface conditions.

In survey after survey, accidents caused by falls are high on the list of disabling and lost-time injuries and death. In fact, statistics from many states rate this type of accident second as the cause for industry's loss of manhours and lower productivity. As proved in the test described above, GRIP STRUT safety grating substantially reduces this kind of accident. In addition, the hazard of falling objects is minimized by the shape and size (1⁷/₈" x 1¹/₁₆") of the surface openings.



Test Performance – Slip Resistance vs. Federal Specifications

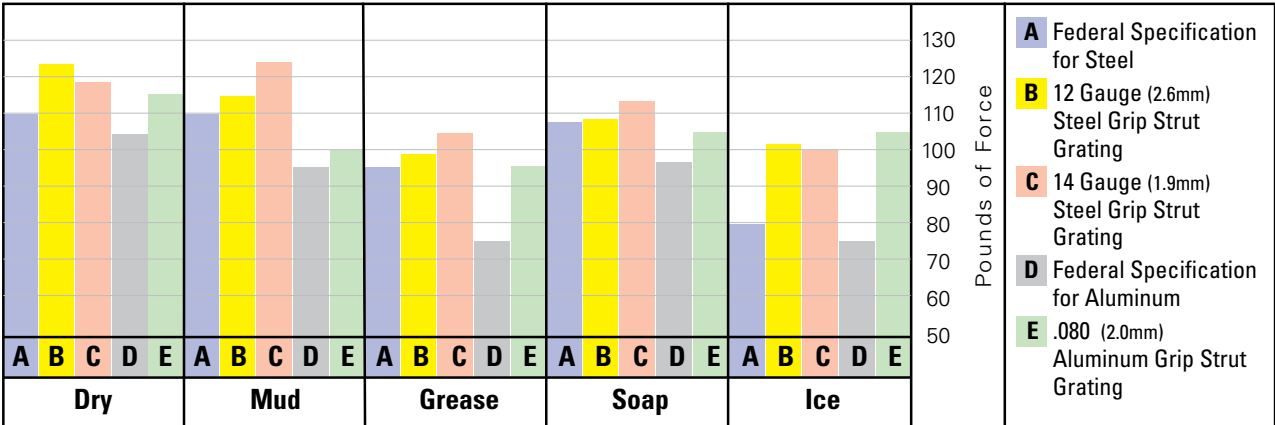

Values determined in accordance with standards for slip-resistance established by Federal Specification RR-G-1602D. The values indicated are an average of values obtained for five sole materials (leather, boot rubber, shoe rubber, Neolite† and Hypalon†) tested in three directions (longitudinally, transversely and diagonally) for the surface conditions noted. Values are in pounds of force necessary to move a 175 pound load one inch across the surface of grating.

† Mark shown is the property of its respective owner.

General Load Information

How To Read Load Tables

To select size of GRIP STRUT™ safety grating, determine load, clear span and deflection requirements. Having this information, select from load tables the appropriate plank to meet job requirements.

Example: Clear span of 4'-0", concentrated load requirement of 300 lbs. at 0.25" maximum deflection.

Select from the tables following:

For 8-diamond, 18³/₄" wide, 2¹/₂" channel, 12 gauge steel which carries a load of 416 lbs. at a 0.18" deflection. This is one size to do the job. Other sizes will carry more load if necessary. For more economical selection, choose the greatest width that will support the load consistent with job requirements and choose deeper channels rather than heavier steel gauges.

GRIP STRUT safety grating will generally carry the same concentrated load, tabulated in lbs. at midspan, for a given span, material gauge and channel height, regardless of width. (See "How load tables were prepared" described below.) The uniform load tables are tabulated in lbs./sq.ft., which accounts for the difference in load capacity shown for various widths. Deflection is in inches.

How Load Tables Were Prepared

The values shown in the following tables are based on actual load tests conducted in accordance with the provisions of the AISI Specification for the Design of Cold-Formed Steel Structural Members, 1986 Edition. To help ensure the safety of the tabulated loads, two aspects of GRIP STRUT safety grating must be considered.

The first consideration is transverse bending in the grating surface, which is referred to as "strut flexure". This occurs when the grating is loaded with either a uniform load or a mid-width concentrated load, and the "struts" (grating surface) deflect relative to the side channels. To determine the allowable strut loads, samples of each grating material and thickness were tested for each plank width. (See Figure 1a below and 2a on the following page). The data resulting from these tests was used to prepare "strut loading" tables, which give allowable loads and deflections considering strut flexure only. These allowable strut loads, along with the results of additional tests performed on 8- and 10-Diamond grating, have been incorporated in the Product Selection/Design Tables on pages 6 through 17.

The second aspect of GRIP STRUT safety grating strength is channel flexure. This occurs when the channels at mid-span of

the plank deflect relative to support points. To verify the performance of the side channels, samples were loaded with concentrated and uniform loads at different spans (see Figures 1b/2b and 1c/2c). To approximate the most severe condition, there were no attachments between the channels and the supports. In cases where spans are shorter, channels deeper and planks wider, strut flexure becomes more critical.

2-, 3-, 4- and 5-Diamond Allowable Load and Deflection Tables

Since 2- through 5-Diamond planks are relatively narrow (less than 1 foot wide), it can be assumed that both side channels effectively support the concentrated load and that the grating surface deflection is negligible. Based upon these assumption, the values in the following Design Tables for 2-Diamond through 5-Diamond have been determined.

Allowable Uniform Load (U)

Values indicated in the rows adjacent to "U" are the lowest of the (1) maximum allowable uniform loads considering channel flexure and (2) maximum grating surface flexure.

Deflection Corresponding to "U"

Deflection values are indicated below the uniform loads and are in the mid-span side channel deflections for the planks carrying the allowable uniform loads (Figure 1c and 2c).

Allowable Concentrated Load (C)

Values indicated in the rows labeled "C" are the lowest of the (1) maximum allowable concentrated load considering channel flexure (Figure 1b and 2b), with both channels effective, and (2) the maximum allowable strut load (C_s) for a 1 foot long sample (Figure 1a and 2a).

Deflection Corresponding to "C"

Deflection values indicated below "C" values in the tables are the mid-span, side channel deflections produced when the allowable concentrated load is placed at mid-span.

If grating surface deflection should be considered when selecting a product to meet a particular specification, then the deflection of the mid-width of the grating, relative to the side channels, can be calculated using both the data in the Strut Loading Tables (pages 6 -17) and the Load/Deflection Conversion formula on top of following page.

Load data based on yield strength of 33,000 psi for steel, 23,000 psi for aluminum, 35,000 psi for Type 304 stainless steel, and 30,000 psi for Type 316L stainless steel.

Figure 1a - Strut Load

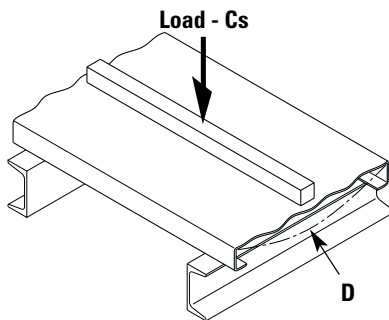

C_s - Concentrated Strut Load (lb./ft.)

Figure 1b - Concentrated Load

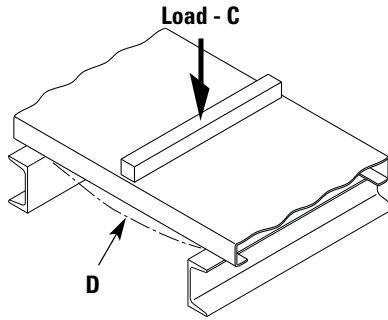

C - Concentrated Load (lb.)

Figure 1c - Uniform Load

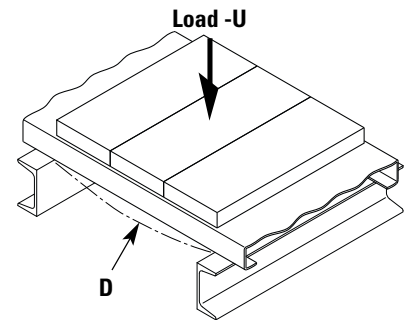

U - Uniform Load (lb./ft.²)

D = Deflection (in.)

General Load Information

Load/Deflection Conversion Formulas

In the elastic range, deflection is proportional to the applied load for both uniform and concentrated loads. This relationship can be used to determine the deflection that any load which is less than the allowable load will produce, as shown in Example A. Also, if desired, the load which will produce a specific deflection can also be determined if the load is in the elastic range as illustrated in Example B.

Example A

What deflection will a 300 lb. concentrated load produce on a plank (catalog number 103012) spanning 5'-0"?

See page 16 for item 103012 at a span = 5'-0" C = 480 lb. D = D @ 300 lb. = $0.26''/480 \text{ lb.} \times 300 \text{ lb.} = 0.16''$

Example B

If a plank (catalog number 103012) is spanning 6'-0", what concentrated load will produce a 1/4" deflection?

See page 16 for item 103012 at a span = 6'-0" C = 400 lb. D = 0.26" C @ 1/4" = $400 \text{ lb.}/0.26'' \times 0.25'' = 385 \text{ lb.}$

8- and 10-Diamond Allowable Load and Deflection Tables

As width increases, grating strut flexure becomes much more important. 8-Diamond and 10-Diamond products are wide enough to require a change in the assumptions used to prepare the 2-Diamond through 5-Diamond Product Selection/Design Tables. No longer will it be assumed that both side channels are equally effective in supporting a concentrated load. In fact, to provide a high level of safety, one side channel will be required to carry 100% of a concentrated load.

Also strut deflection for 8-Diamond and 10-Diamond products may be significant. The most critical case occurs when a concentrated load is located at mid-span and mid-width. To determine how the struts perform under this loading, 3 foot long samples of each material and thickness were tested. For these tests the side channels were continuously supported and loads were applied using a 1 foot long and 1 inch wide bar placed parallel to the side channels at mid-width and at the longitudinal center.

Results of these tests, included in the 8-Diamond and 10-Diamond Product Design Tables, proved the performance of these materials when a concentrated load is applied at mid-span and mid-width. If a concentrated load is to be applied at mid-width at the end of a plank, consult the Strut Loading Tables (pages 6-17).

The following values have been tabulated for 8-Diamond and 10-Diamond grating:

Allowable Uniform Load (U)

Values are given in the rows labeled "U" and are the lowest of the (1) maximum allowable uniform loads considering channel flexure, and (2) maximum grating surface flexure.

Deflection Corresponding to "U"

Deflection values appear in the rows labeled "D", below the "U" values, and are maximum deflections the allowable uniform loads would produce. Maximum deflections will occur at mid-span and mid-width and will be the sum of side channel and grating surface deflections (Figure 1c and 2c).

Allowable Concentrated Load (C)

Values tabulated in the rows labeled "C" are the lowest of the (1) maximum allowable concentrated load considering side channel flexure (with one side channel supporting the entire load — Figure 2b, and (2) the maximum allowable strut flexure (Figure 2a).

Deflection Corresponding to "C"

Deflection values are indicated below "C" values in the table and are deflections the allowable concentrated load will produce at mid-span and at the mid-width. The deflection is the sum of side channel and grating surface deflections

Figure 2a - Strut Load

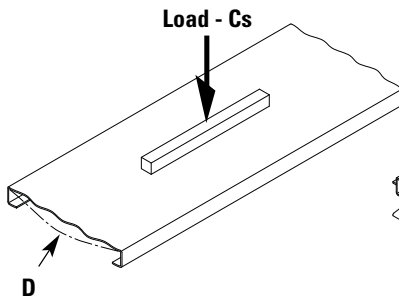

Figure 2b - Concentrated Load

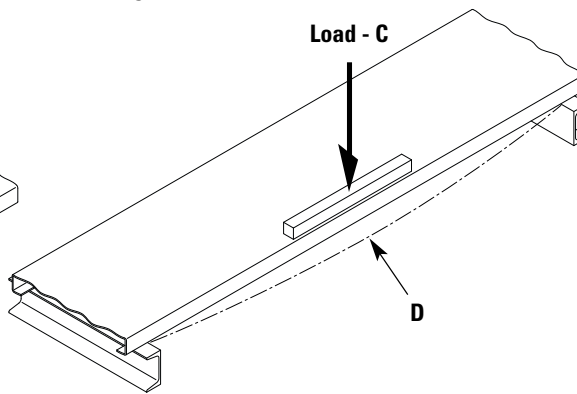
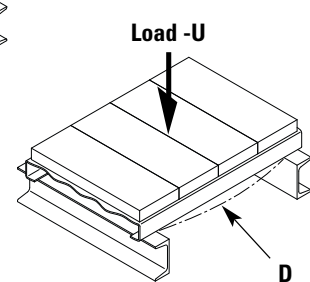

Figure 2c - Uniform Load



D = Deflection (in.)

Safe Loading Tables

2-Diamond Plank — 4³/₄" Width

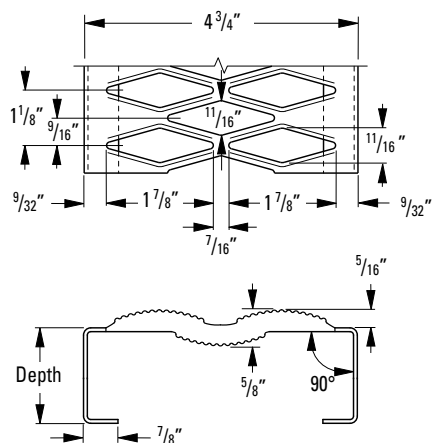

Product Selection/Design Tables

Allowable Loads and Deflections: U=Uniform Load (lb./ft.²) C= Concentrated Load (lb.) D=Deflection (in.)
Spans to the left of heavy red line produce a deflection of 1/4" or less under a uniform load of 100 lb./ft.²

Material Gauge	Channel Depth in. (mm)	Weight lb./lin. ft. (kg/m)	Catalog Number		Span																					
					2'-0"	2'-6"	3'-0"	3'-6"	4'-0"	4'-6"	5'-0"	5'-6"	6'-0"	6'-6"	7'-0"	7'-6"	8'-0"	9'-0"	10'-0"	11'-0"	12'-0"					
Steel 14 ga.	1 1/2" (38.1)	2.3 (3.42)	21514	U	1324	849	591	435	334	265	215	179	151													
				D	.06	.10	.14	.20	.26	.32	.40	.49	.58													
				C	524	420	351	301	265	236	213	195	179													
					D	.05	.08	.11	.16	.20	.26	.32	.39	.47												
		2" (50.8)	2.6 (3.87)	22014	U	2198	1409	980	721	553	438	356	295	248	212	184	161	142	113	93						
	D				.06	.09	.13	.17	.23	.29	.35	.43	.51	.60	.70	.81	.92	1.18	1.47							
	C				870	697	582	499	438	390	352	321	295	273	255	239	225	201	183							
					D	.04	.07	.10	.14	.18	.23	.28	.34	.41	.48	.56	.65	.74	.94	1.18						
		2 1/2" (63.5)	2.8 (4.17)	22514	U	2522	1616	1124	827	634	502	408	338	285	244	211	184	163	139	106	88	75				
	D				.04	.06	.08	.11	.14	.18	.23	.27	.33	.38	.45	.51	.59	.75	.94	1.14	1.38					
	C				998	800	667	573	502	447	404	368	338	313	292	273	257	231	210	193	178					
					D	.03	.04	.06	.09	.11	.15	.18	.22	.26	.31	.36	.41	.47	.60	.75	.92	1.10				
Steel 12 ga.	1 1/2" (38.1)	3.2 (4.76)	21512	U	1751	1123	782	576	443	351	286	237	200	172	149	131	116									
				D	.07	.11	.15	.21	.27	.35	.43	.52	.62	.74	.86	.99	1.14									
				C	693	556	464	399	350	313	283	258	238	221	206	194	183									
					D	.05	.08	.12	.17	.22	.28	.34	.42	.50	.59	.69	.79	.91								
		2" (50.8)	3.6 (5.36)	22012	U	2792	1790	1245	917	703	557	453	375	317	271	235	205	181	145	119	99	85				
	D				.05	.08	.11	.16	.20	.26	.32	.39	.46	.55	.63	.73	.84	1.07	1.34	1.64	1.98					
	C				1105	886	739	635	557	496	448	409	376	348	325	305	287	258	235	216	201					
					D	.04	.06	.09	.12	.16	.21	.26	.31	.37	.44	.51	.59	.67	.86	1.07	1.31	1.58				
		2 1/2" (63.5)	4.0 (5.95)	22512	U	4179	2676	1860	1368	1049	830	673	557	469	400	346	302	266	211	172	143	121				
	D				.04	.06	.09	.13	.17	.21	.26	.32	.38	.44	.51	.59	.67	.86	1.07	1.30	1.55					
	C				1654	1324	1104	948	830	739	666	606	557	515	479	448	421	376	341	312	288					
					D	.03	.05	.07	.10	.13	.17	.21	.25	.30	.35	.41	.47	.54	.69	.85	1.04	1.24				

Safe Loading Tables

2-Diamond Plank — 4³/₄" Width

Product Selection/Design Tables

Allowable Loads and Deflections: U=Uniform Load (lb./ft.) C= Concentrated Load (lb.) D=Deflection (in.)
Spans to the left of heavy red line produce a deflection of 1/4" or less under a uniform load of 100 lb./ft.:

Material Gauge	Channel Depth in. (mm)	Weight lb./in. (kg/m)	Catalog Number	Span																	
				2'-0"	2'-6"	3'-0"	3'-6"	4'-0"	4'-6"	5'-0"	5'-6"	6'-0"	6'-6"	7'-0"	7'-6"	8'-0"	8'-6"	9'-0"	9'-6"	10'-0"	
Alum. Alloy 5052 .080"	1 1/2" (38.1)	.85 (1.26)	21512-A	U	998	639	443	326	248	196	159	131	110	94							
				D	.10	.15	.22	.31	.40	.51	.63	.76	.90	1.08							
				C	395	316	263	226	197	175	157	143	131	121							
	2"	.92 (1.37)	22012-A	U	1463	937	650	478	366	289	234	194	162	138	119						
				D	.08	.13	.18	.25	.33	.42	.52	.63	.74	.87	1.02						
				C	579	463	386	331	290	257	232	211	192	177	165						
	2 1/2" (63.5)	1.00 (1.48)	22512-A	U	2199	1407	977	718	550	434	352	291	244	208	179	156	137				
				D	.07	.10	.15	.21	.28	.35	.43	.53	.63	.74	.85	.98	1.12				
				C	870	696	580	497	435	387	348	316	290	268	249	232	218				
Alum. Alloy 5052 .100"	1 1/2" (38.1)	1.08 (1.60)	21510-A	U	1136	727	505	371	284	224	181	149	125	107							
				D	.09	.15	.22	.30	.39	.50	.63	.76	.90	1.08							
				C	450	360	300	257	225	200	179	162	149	137							
	2"	1.20 (1.78)	22010-A	U	2049	1312	911	669	512	405	328	271	228	194	167	146	128				
				D	.09	.14	.20	.28	.37	.46	.58	.70	.83	.98	1.13	1.30	1.48				
				C	811	649	541	464	406	361	325	295	270	250	232	216	203				
	2 1/2" (63.5)	1.31 (1.95)	22510-A	U	2820	1805	1253	921	705	557	451	373	313	267	230	201	176				
				D	.07	.11	.16	.22	.28	.36	.45	.54	.64	.76	.88	1.01	1.15				
				C	1116	893	744	638	558	496	446	406	372	343	319	298	279				
D	.05	.09	.12	.17	.23	.29	.36	.43	.51	.60	.70	.81	.92								

* Available on special order.

Engineering Data For Both Channels

Material Gauge	Channel Depth in.	Sx in. ²	Ix in. ⁴	EI lb. x in. ²
Steel 14 ga.	1 1/2"	.174	.102	2.96 x 10 ⁶
	2"	.270	.193	5.60 x 10 ⁶
	2 1/2"	.307	.335	9.71 x 10 ⁶
Steel 12 ga.	1 1/2"	.216	.125	3.62 x 10 ⁶
	2"	.342	.264	7.66 x 10 ⁶
	2 1/2"	.504	.488	14.09 x 10 ⁶
Aluminum .080"	1 1/2"	.171	.137	1.40 x 10 ⁶
	2"	.251	.246	2.51 x 10 ⁶
	2 1/2"	.379	.441	4.50 x 10 ⁶
Aluminum .100"	1 1/2"	.196	.156	1.59 x 10 ⁶
	2"	.352	.309	3.15 x 10 ⁶
	2 1/2"	.456	.544	5.55 x 10 ⁶

Strut Loading

Material Gauge	Type Loading**	Load	Deflection in.
Steel 14 ga.	U	6268	.10
	Cs	1240	.08
Steel 12 ga.	U	8619	.10
	Cs	1705	.08
Aluminum .080"	U	4677	.12
	Cs	925	.10
Aluminum .100"	U	5847	.12
	Cs	1157	.10

** U = Allowable Uniform Load (lb./ft.)
Cs = Allowable Concentrated Load per ft. of length at mid-width (lb./ft.)

Safe Loading Tables

3-Diamond Plank — 7" Width

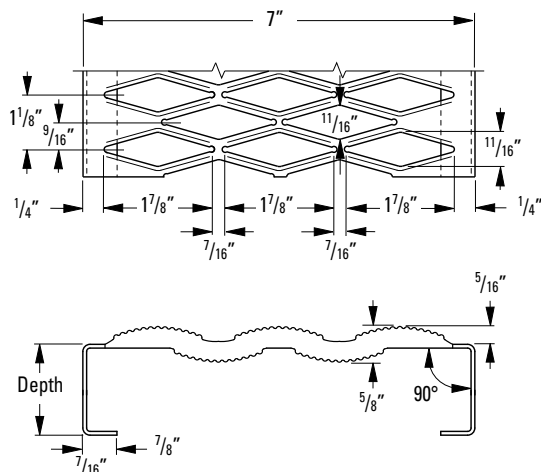

Relief hole available upon request on 3, 4, & 5-diamond planks

Product Selection/Design Tables

Allowable Loads and Deflections: U=Uniform Load (lb./ft.²) C= Concentrated Load (lb.) D=Deflection (in.)
Spans to the left of heavy red line produce a deflection of 1/4" or less under a uniform load of 100 lb./ft.²

Material Gauge	Channel Depth in. (mm)	Weight lb./lin. ft. (kg/m)	Catalog Number	Span																			
				2'-0"	2'-6"	3'-0"	3'-6"	4'-0"	4'-6"	5'-0"	5'-6"	6'-0"	6'-6"	7'-0"	7'-6"	8'-0"	9'-0"	10'-0"	11'-0"	12'-0"			
Steel 14 ga.	1 1/2" (38.1)	3.0 (4.46)	31514	U	899	577	402	269	227	180	147	122	103										
				D	.06	.10	.14	.20	.26	.33	.40	.49	.59										
				C	524	421	351	302	265	237	214	196	180										
				D	.05	.08	.11	.16	.21	.26	.32	.39	.47										
	2" (50.8)	3.2 (4.76)	32014	U	1492	957	665	490	376	298	242	201	169	145	125	110	97	77	63				
				D	.06	.09	.13	.17	.23	.29	.35	.43	.51	.61	.71	.81	.93	1.19	1.49				
				C	871	697	582	500	439	391	353	322	296	275	256	240	226	203	185				
				D	.04	.07	.10	.14	.18	.23	.28	.34	.41	.48	.56	.65	.74	.85	1.19	1.19			
	2 1/2" (63.5)	3.5 (5.21)	32514	U	1712	1097	763	562	431	342	277	230	194	166	144	126	111	89	73	61	52		
				D	.04	.06	.08	.11	.14	.18	.23	.27	.33	.39	.45	.52	.59	.76	.94	1.16	1.40		
				C	999	800	668	574	503	448	405	369	340	315	293	275	259	233	212	195	181		
				D	.03	.04	.06	.09	.11	.15	.18	.22	.26	.31	.36	.41	.47	.61	.76	.93	1.12		
Steel 12 ga.	1 1/2" (38.1)	4.1 (6.10)	31512	U	1189	763	532	392	301	239	195	162	137	118	102	90	79						
				D	.07	.11	.15	.21	.27	.35	.43	.52	.63	.74	.87	1.00	1.15						
				C	694	556	465	400	352	314	284	260	240	223	208	196	185						
				D	.05	.08	.12	.17	.22	.28	.34	.42	.50	.59	.69	.80	.92						
	2" (50.8)	4.5 (6.70)	32012	U	1896	1216	846	623	478	379	308	256	216	185	160	140	124	99	82	68	58		
				D	.05	.08	.11	.16	.20	.26	.32	.39	.47	.55	.64	.74	.85	1.08	1.36	1.67	2.01		
				C	1106	886	740	636	558	498	450	410	378	350	327	307	289	260	238	219	203		
				D	.04	.06	.09	.12	.16	.21	.26	.31	.37	.44	.51	.59	.68	.87	1.09	1.33	1.61		
	2 1/2" (63.5)	4.9 (7.29)	32512	U	2836	1817	1263	929	712	564	457	379	319	272	235	206	181	144	118	98	83		
				D	.04	.06	.09	.13	.17	.21	.26	.32	.38	.44	.52	.59	.68	.86	1.07	1.31	1.57		
				C	1654	1325	1105	948	831	740	667	608	558	516	481	450	423	378	343	314	290		
				D	.03	.05	.07	.10	.13	.17	.21	.25	.30	.35	.41	.47	.54	.69	.86	1.05	1.25		
3" (76.2)	5.2 (7.74)	33012	U	3587	2298	1597	1174	900	712	578	478	403	344	297	259	228	181	148	123	104			
			D	.04	.06	.09	.13	.17	.21	.26	.32	.38	.44	.51	.59	.67	.86	1.07	1.30	1.55			
			C	1868	1675	1397	1199	1050	935	843	767	705	652	606	567	533	476	431	395	364			
			D	.03	.04	.06	.09	.11	.14	.18	.22	.26	.30	.35	.41	.46	.59	.73	.89	1.07			

Safe Loading Tables

3-Diamond Plank — 7" Width

Product Selection/Design Tables

Allowable Loads and Deflections: U=Uniform Load (lb./ft.²) C= Concentrated Load (lb.) D=Deflection (in.)
Spans to the left of heavy red line produce a deflection of 1/4" or less under a uniform load of 100 lb./ft.²

Material Gauge	Channel Depth in. (mm)	Weight lb./in. (kg/m)	Catalog Number	Span																				
				2'-0"	2'-6"	3'-0"	3'-6"	4'-0"	4'-6"	5'-0"	5'-6"	6'-0"	6'-6"	7'-0"	7'-6"	8'-0"	8'-6"	9'-0"	9'-6"	10'-0"				
Alum. Alloy 5052 .080"	1 1/2" (38.1)	1.06 (1.58)	31512-A	U	667	443	301	221	168	133	108													
				D	.10	.15	.22	.31	.40	.51	.63													
				C	395	316	263	226	197	175	157													
				D	.08	.12	.18	.25	.32	.41	.50													
	2"	1.15 (1.71)	32012-A	U	993	636	441	324	248	196	159	131	110	93	80									
				D	.08	.13	.18	.25	.33	.42	.52	.63	.74	.86	1.00									
				C	579	463	386	331	290	257	232	211	192	177	165									
				D	.06	.10	.15	.20	.27	.34	.42	.51	.59	.69	.80									
	2 1/2" (63.5)	1.24 (1.85)	32512-A	U	1492	955	663	487	373	295	239	197	166	141	122	106	93							
				D	.07	.10	.15	.21	.28	.35	.43	.53	.63	.74	.85	.98	1.12							
				C	812	696	580	497	435	387	348	316	290	268	249	232	218							
				D	.05	.08	.12	.17	.22	.28	.35	.42	.50	.59	.68	.78	.89							
3" (76.2)	1.33 (1.98)	33012-A	U	1833	1173	815	598	458	362	293	242	204	174	150	130	115								
			D	.06	.09	.14	.19	.25	.31	.39	.47	.56	.66	.77	.88	1.00								
			C	846	846	713	611	535	475	428	389	356	329	305	285	267								
			D	.03	.07	.11	.15	.20	.25	.31	.38	.45	.53	.61	.70	.80								
Alum. Alloy 5052 .100"	1 1/2" (38.1)	1.34 (1.99)	31510-A	U	771	494	343	252	193	152	122	101												
				D	.09	.15	.22	.30	.39	.50	.63	.76												
				C	450	360	300	257	225	200	179	162												
				D	.07	.12	.17	.24	.31	.40	.51	.61												
	2"	1.46 (2.38)	32010-A	U	1391	890	618	454	348	275	223	184	155	132	114	99	87							
				D	.09	.14	.20	.28	.37	.46	.58	.70	.83	.98	1.13	1.30	1.48							
				C	811	649	541	464	406	361	325	295	270	250	232	216	203							
				D	.07	.11	.16	.22	.29	.37	.46	.56	.66	.78	.90	1.04	1.18							
	2 1/2" (63.5)	1.57 (2.34)	32510-A	U	1913	1225	850	625	478	378	306	253	213	181	156	136	120							
				D	.07	.11	.16	.22	.28	.36	.45	.54	.64	.76	.88	1.01	1.15							
				C	1116	893	744	638	558	496	446	406	372	343	319	298	279							
				D	.05	.09	.12	.17	.23	.29	.36	.43	.51	.60	.70	.81	.92							
3" (76.2)	1.68 (2.50)	33010-A	U	2470	1581	1098	807	618	488	395	327	274	234	202	176	154								
			D	.05	.08	.12	.17	.22	.28	.34	.42	.50	.59	.68	.78	.89								
			C	1309	1153	961	823	720	640	576	524	480	443	412	384	360								
			D	.04	.06	.10	.13	.17	.22	.27	.33	.40	.47	.54	.62	.71								

* Available on special order.

Engineering Data For Both Channels

Material Gauge	Channel Depth in.	Sx in. ²	Ix in. ⁴	EI lb. x in. ²
Steel 14 ga.	1 1/2"	.174	.102	2.96 x 10 ⁶
	2"	.270	.193	5.60 x 10 ⁶
	2 1/2"	.307	.335	9.71 x 10 ⁶
Steel 12 ga.	1 1/2"	.216	.125	3.62 x 10 ⁶
	2"	.342	.264	7.66 x 10 ⁶
	2 1/2"	.504	.488	14.09 x 10 ⁶
Aluminum .080"	3"	.625	.722	20.94 x 10 ⁶
	1 1/2"	.171	.137	1.40 x 10 ⁶
	2"	.251	.246	2.51 x 10 ⁶
Aluminum .100"	2 1/2"	.379	.441	4.50 x 10 ⁶
	3"	.464	.602	6.14 x 10 ⁶
	1 1/2"	.196	.156	1.59 x 10 ⁶
Aluminum .100"	2"	.352	.309	3.15 x 10 ⁶
	2 1/2"	.456	.544	5.55 x 10 ⁶
	3"	.627	.911	9.29 x 10 ⁶

Strut Loading

Material Gauge	Type Loading**	Load	Deflection in.
Steel 14 ga.	U	3535	.11
	Cs	1031	.09
Steel 12 ga.	U	6405	.11
	Cs	1868	.09
Aluminum .080"	U	2901	.15
	Cs	846	.12
Aluminum .100"	U	4488	.16
	Cs	1309	.13

** U = Allowable Uniform Load (lb./ft.²)
Cs = Allowable Concentrated Load per ft. of length at mid-width (lb./ft.)

Safe Loading Tables

4-Diamond Plank — 9 1/2" Width (available in stainless steel)

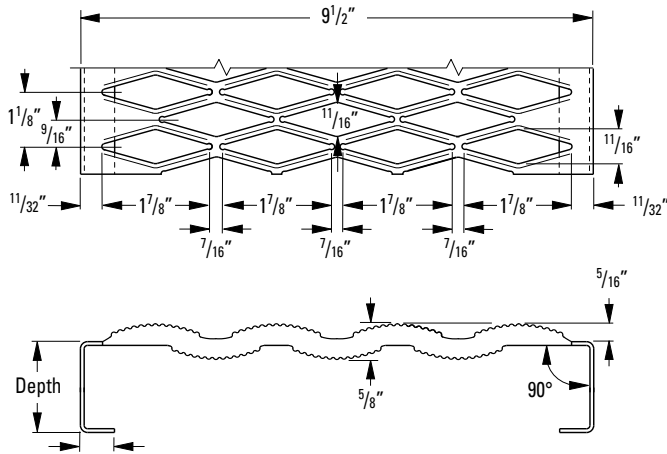

Relief hole available upon request on 3, 4, & 5-diamond planks

Product Selection/Design Tables

Allowable Loads and Deflections: U=Uniform Load (lb./ft.²) C= Concentrated Load (lb.) D=Deflection (in.)
Spans to the left of heavy red line produce a deflection of 1/4" or less under a uniform load of 100 lb./ft.²

Material Gauge	Channel Depth in. (mm)	Weight lb./lin. ft. (kg/m)	Catalog Number	Span																				
				2'-0"	2'-6"	3'-0"	3'-6"	4'-0"	4'-6"	5'-0"	5'-6"	6'-0"	6'-6"	7'-0"	7'-6"	8'-0"	9'-0"	10'-0"	11'-0"	12'-0"				
Steel 14 ga.	1 1/2" (38.1)	3.6 (5.36)	41514	U	663	426	296	219	168	134	109	90	77											
				D	.06	.10	.14	.20	.26	.33	.41	.50	.59											
				C	525	421	352	303	266	238	215	197	182											
				D	.05	.08	.11	.16	.21	.26	.33	.40	.47											
	2" (50.8)	3.8 (5.65)	42014	U	1100	705	491	362	278	220	179	148	125	107	93	81	72	58	47					
				D	.06	.09	.13	.17	.23	.29	.36	.43	.52	.61	.71	.82	.94	1.20	1.51					
				C	730	698	583	501	440	392	354	323	298	276	258	242	228	205	187					
				D	.04	.07	.10	.14	.18	.23	.28	.35	.41	.49	.57	.66	.75	.96	1.20					
	2 1/2" (63.5)	4.1 (6.10)	42514	U	1262	809	563	415	318	252	205	170	144	123	106	93	82	66	54	45				
				D	.04	.06	.08	.11	.14	.18	.23	.28	.33	.39	.45	.52	.60	.76	.95	1.17				
				C	730	730	669	574	504	449	406	370	341	316	295	277	261	235	214	197				
				D	.02	.04	.06	.09	.12	.15	.18	.22	.26	.31	.36	.42	.48	.61	.76	.94				
Steel 12 ga.	1 1/2" (38.1)	5.0 (7.44)	41512	U	906	581	405	298	229	182	148	123	104	89	77	67	60							
				D	.07	.11	.16	.21	.28	.36	.44	.54	.64	.76	.89	1.02	1.17							
				C	718	575	481	413	363	324	292	267	246	228	213	200	189							
				D	.06	.09	.13	.17	.23	.29	.35	.43	.52	.61	.71	.82	.94							
	2" (50.8)	5.4 (8.04)	42012	U	1398	896	624	460	353	280	228	189	160	137	119	104	92	74	61	51	43			
				D	.05	.08	.11	.16	.20	.26	.32	.39	.47	.55	.65	.75	.85	1.10	1.38	1.69	2.03			
				C	1107	887	741	637	559	499	451	412	380	353	329	309	292	264	241	222	206			
				D	.04	.06	.09	.12	.16	.21	.26	.31	.37	.44	.52	.60	.68	.88	1.10	1.35	1.63			
	2 1/2" (63.5)	5.7 (8.48)	42512	U	2090	1339	931	685	525	416	338	280	236	201	174	152	134	107	87	73	62			
				D	.04	.06	.09	.13	.17	.21	.26	.32	.38	.44	.52	.60	.68	.87	1.08	1.32	1.58			
				C	1400	1325	1106	949	832	741	668	609	559	518	482	452	425	380	345	316	293			
				D	.03	.05	.07	.10	.13	.17	.21	.25	.30	.36	.41	.48	.54	.69	.86	1.05	1.27			
3" (76.2)	6.1 (9.08)	43012	U	2644	1694	1177	866	664	525	426	353	297	254	219	192	169	134	110	91	77				
			D	.04	.06	.08	.11	.14	.18	.22	.27	.32	.38	.44	.51	.58	.74	.92	1.12	1.35				
			C	1400	1400	1398	1200	1051	936	844	769	706	653	608	569	535	478	434	397	367				
			D	.02	.04	.06	.09	.11	.15	.18	.22	.26	.31	.35	.41	.47	.59	.74	.90	1.08				
Stainless Steel 304 16 ga.	2" (50.8)	3.2 (4.76)	42016-S	U	720	462	322	238	183	145	118	98	83	71	59									
				D	.05	.08	.11	.16	.20	.26	.32	.39	.47	.55	.61									
				C	570	457	382	329	289	258	234	214	197	184	165									
				D	.04	.06	.09	.12	.16	.21	.26	.31	.38	.44	.49									
Stainless Steel 316L 16 ga.	2" (50.8)	3.2 (4.76)	42016-SL	U	626	400	278	204	156	123	100	82	69	59	51									
				D	.04	.06	.10	.13	.17	.22	.27	.32	.39	.45	.53									
				C	492	397	330	283	248	220	198	180	165	152	141									
				D	.03	.05	.08	.10	.14	.17	.22	.26	.31	.36	.42									

Safe Loading Tables

4-Diamond Plank — 9 1/2" Width (available in stainless steel)

Product Selection/Design Tables

Allowable Loads and Deflections: U=Uniform Load (lb./ft.) C= Concentrated Load (lb.) D=Deflection (in.)
Spans to the left of heavy red line produce a deflection of 1/4" or less under a uniform load of 100 lb./ft.†

Material Gauge	Channel Depth in. (mm)	Weight lb./lin. ft. (kg/m)	Catalog Number	Span																
				2'-0"	2'-6"	3'-0"	3'-6"	4'-0"	4'-6"	5'-0"	5'-6"	6'-0"	6'-6"	7'-0"	7'-6"	8'-0"	9'-0"	10'-0"	11'-0"	12'-0"
Alum. Alloy 5052 .080"	1 1/2"* (38.1)	1.28 (1.90)	41512-A	U	499	319	222	163	124	98										
				D	.10	.15	.22	.31	.40	.51										
				C	395	316	263	226	197	175										
					D	.08	.12	.18	.25	.32	.41									
		2" (50.8)	1.37 (2.03)	42012-A	U	732	468	325	239	183	145	117	97	81	69					
	D				.08	.13	.18	.25	.33	.42	.52	.63	.74	.87						
	C				568	463	386	331	290	257	232	211	192	177						
					D	.06	.10	.15	.20	.27	.34	.42	.51	.59	.69					
		2 1/2"* (63.5)	1.46 (2.17)	42512-A	U	1099	704	489	359	275	217	176	145	122	104	90	78	69		
	D				.07	.10	.15	.21	.28	.35	.43	.53	.63	.74	.85	.98	1.12			
	C				568	568	568	497	435	387	348	316	290	268	249	232	218			
					D	.05	.07	.12	.17	.22	.28	.35	.42	.50	.59	.68	.78	.89		
	3"* (76.2)	1.55 (2.30)	43012-A	U	1350	864	600	441	338	267	216	179	150	128	110	96	84			
D				.06	.09	.14	.19	.25	.31	.39	.47	.56	.66	.77	.88	1.00				
C				568	568	568	568	535	475	428	389	356	329	305	285	267				
				D	.02	.05	.09	.14	.20	.25	.31	.38	.45	.53	.61	.70	.80			
Alum. Alloy 5052 .100"	1 1/2"* (38.1)	1.62 (2.41)	41510-A	U	568	364	253	186	142	112										
				D	.09	.15	.22	.30	.39	.50										
				C	450	360	300	257	225	200										
					D	.07	.12	.17	.24	.31	.40									
		2" (50.8)	1.74 (2.58)	42010-A	U	1025	656	455	335	256	202	164	136	114	97	84	73	64		
	D				.09	.14	.20	.28	.37	.46	.58	.70	.83	.98	1.13	1.30	1.48			
	C				811	649	541	464	406	361	325	295	270	250	232	216	203			
					D	.07	.11	.16	.22	.29	.37	.46	.56	.66	.78	.90	1.04	1.18		
		2 1/2"* (63.5)	1.85 (2.75)	42510-A	U	1410	902	627	460	352	278	226	186	157	133	115	100	88		
	D				.07	.11	.16	.22	.28	.36	.44	.54	.64	.76	.88	1.01	1.15			
	C				886	886	744	638	558	496	446	406	372	343	319	298	279			
					D	.05	.09	.12	.17	.23	.29	.36	.43	.51	.60	.70	.81	.92		
	3"* (76.2)	1.97 (2.93)	43010-A	U	1820	1165	809	594	455	360	291	241	202	172	149	129	114			
D				.05	.08	.12	.17	.22	.28	.34	.42	.50	.59	.68	.78	.89				
C				886	886	886	823	720	640	576	524	480	443	412	384	360				
				D	.02	.05	.09	.13	.17	.22	.27	.33	.40	.47	.54	.62	.71			

* Available on special order.

Engineering Data For Both Channels

Material Gauge	Channel Depth - in.	Sx in. ²	Ix in. ⁴	E I lb. x in. ²
Steel 14 ga.	1 1/2"	.174	.102	2.96 x 10 ⁶
	2"	.270	.193	5.60 x 10 ⁶
	2 1/2"	.307	.335	9.71 x 10 ⁶
Steel 12 ga.	1 1/2"	.216	.125	3.62 x 10 ⁶
	2"	.342	.264	7.66 x 10 ⁶
	2 1/2"	.504	.488	14.09 x 10 ⁶
	3"	.625	.722	20.94 x 10 ⁶
Aluminum .080"	1 1/2"	.171	.137	1.40 x 10 ⁶
	2"	.251	.246	2.51 x 10 ⁶
	2 1/2"	.379	.441	4.50 x 10 ⁶
	3"	.464	.602	6.14 x 10 ⁶
Aluminum .100"	1 1/2"	.196	.156	1.59 x 10 ⁶
	2"	.352	.309	3.15 x 10 ⁶
	2 1/2"	.486	.544	5.55 x 10 ⁶
	3"	.627	.911	9.29 x 10 ⁶
Stainless 304 16 ga.	2"	.165	.1425	4.13 x 10 ⁶
Stainless 316L 16 ga.	2"	.165	.1425	4.13 x 10 ⁶

Strut Loading

Material Gauge	Type Loading**	Load	Deflection in.
Steel 14 ga.	U	1844	.15
	Cs	730	.11
Steel 12 ga.	U	3537	.14
	Cs	1400	.11
Aluminum .080"	U	1435	.19
	Cs	568	.15
Aluminum .100"	U	2238	.23
	Cs	886	.15
Stainless 304 16 ga.	U	1450	.29
	Cs	574	.19
Stainless 316L 16 ga.	U	1243	.20
	Cs	492	.16

** U = Allowable Uniform Load (lb./ft.)
Cs = Allowable Concentrated Load per ft. of length at mid-width (lb./ft.)

Safe Loading Tables

5-Diamond Plank — 11³/₄" Width (available in stainless steel)

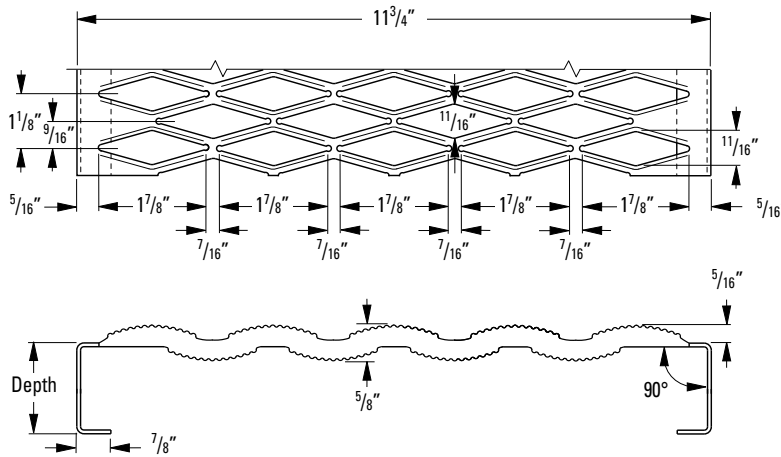

Relief hole available upon request on 3, 4, & 5-diamond planks

Product Selection/Design Tables

Allowable Loads and Deflections: U=Uniform Load (lb./ft.²) C= Concentrated Load (lb.) D=Deflection (in.)
Spans to the left of heavy red line produce a deflection of 1/4" or less under a uniform load of 100 lb./ft.²

Material Gauge	Channel Depth in. (mm)	Weight lb./lin. (kg/m)	Catalog Number	Span																						
				2'-0"	2'-6"	3'-0"	3'-6"	4'-0"	4'-6"	5'-0"	5'-6"	6'-0"	6'-6"	7'-0"	7'-6"	8'-0"	9'-0"	10'-0"	11'-0"	12'-0"						
Steel 14 ga.	1 1/2" (38.1)	4.2 (6.25)	51514	U	536	344	240	177	136	108	88	74	62													
				D	.06	.10	.14	.20	.26	.33	.41	.50	.60													
				C	525	422	353	304	267	239	216	198	183													
				D	.05	.08	.12	.16	.21	.26	.33	.40	.48													
	2" (50.8)	4.4 (6.55)	52014	U	890	571	397	293	225	178	145	120	102	87	76	66	59	47								
				D	.06	.09	.13	.17	.23	.29	.36	.43	.52	.61	.71	.83	.95	1.21								
				C	707	699	584	502	440	393	355	324	299	277	259	243	230	207								
				D	.04	.07	.10	.14	.18	.23	.29	.35	.42	.49	.57	.66	.76	.87	.97							
	2 1/2" (63.5)	4.7 (6.99)	52514	U	1021	655	456	336	258	204	166	138	116	100	86	76	67	54	44							
				D	.04	.06	.08	.11	.14	.18	.23	.28	.33	.39	.45	.52	.60	.70	.81	.96						
				C	707	707	669	575	505	450	407	371	342	317	296	278	262	236	216							
				D	.02	.04	.06	.09	.12	.15	.18	.22	.26	.31	.36	.42	.48	.55	.62	.71	.82	.94				
Steel 12 ga.	1 1/2" (38.1)	5.9 (8.78)	51512	U	710	456	318	235	181	144	117	98	83	71	62	55	49									
				D	.07	.11	.15	.21	.27	.35	.44	.53	.64	.76	.89	1.03	1.18									
				C	695	558	467	402	354	317	287	263	244	227	213	201	190									
				D	.05	.08	.12	.17	.22	.28	.35	.43	.51	.60	.71	.82	.95									
	2" (50.8)	6.2 (9.23)	52012	U	1131	725	505	372	286	227	185	154	130	111	97	85	75	60	50	42						
				D	.05	.08	.11	.16	.20	.26	.32	.39	.47	.56	.65	.75	.86	1.11	1.39	1.70						
				C	1107	888	742	638	561	501	453	414	382	355	332	312	295	266	243	224						
				D	.04	.06	.09	.12	.16	.21	.26	.31	.38	.44	.52	.60	.69	.79	.89	1.11	1.36					
	2 1/2" (63.5)	6.6 (9.82)	52512	U	1691	1083	753	554	425	337	273	226	151	141	123	109	87	71	59	59	50					
				D	.04	.06	.09	.13	.17	.21	.26	.32	.38	.45	.52	.60	.68	.77	1.09	1.33	1.60					
				C	1115	1115	1106	950	833	742	669	610	561	519	484	453	426	382	347	319	295					
				D	.02	.04	.07	.10	.13	.17	.21	.25	.30	.36	.41	.48	.55	.63	.72	.82	.93	1.06	1.28			
3" (76.2)	7.0 (10.40)	53012	U	2138	1370	952	701	537	425	345	286	241	206	178	155	137	109	89	74	63						
			D	.04	.06	.08	.11	.14	.18	.22	.27	.32	.38	.44	.51	.58	.74	.93	1.13	1.36						
			C	1115	1115	1115	1115	1052	937	845	770	707	654	609	570	537	480	436	399	369						
			D	.02	.03	.05	.08	.11	.15	.18	.22	.26	.31	.36	.41	.47	.55	.64	.74	.85	1.09	1.36				
Stainless 304 16 ga.	2" (50.8)	3.7 (5.51)	52016-S	U	583	374	261	192	148	118	96	80	68	58	48											
				D	.05	.08	.11	.16	.20	.26	.32	.39	.47	.56	.66	.78										
				C	464	458	323	330	290	259	235	215	199	185	165											
				D	.03	.06	.09	.12	.16	.21	.26	.32	.38	.45	.53	.62	.72									
Stainless 316L 16 ga.	2" (50.8)	3.7 (5.51)	52016-SL	U	406	324	225	165	126	100	81	66	56	47												
				D	.04	.06	.10	.13	.17	.22	.27	.32	.39	.45												
				C	398	397	330	283	248	220	198	180	165	152												
				D	.03	.05	.08	.10	.14	.17	.22	.26	.31	.36												

Safe Loading Tables

5-Diamond Plank — 11³/₄" Width (available in stainless steel)

Product Selection/Design Tables

Allowable Loads and Deflections: U=Uniform Load (lb./ft.²) C= Concentrated Load (lb.) D=Deflection (in.)
Spans to the left of heavy red line produce a deflection of 1/4" or less under a uniform load of 100 lb./ft.²

Material Gauge	Channel Depth in. (mm)	Weight lb./in. ft. (kg/m)	Catalog Number	Span																			
				2'-0"	2'-6"	3'-0"	3'-6"	4'-0"	4'-6"	5'-0"	5'-6"	6'-0"	6'-6"	7'-0"	7'-6"	8'-0"	9'-0"	10'-0"	11'-0"	12'-0"			
Alum. Alloy 5052 .080"	1 1/2" (38.1)	1.49 (2.22)	51512-A	U	403	255	179	132	100														
				D	.10	.15	.22	.31	.40														
				C	395	316	263	226	197														
				D	.08	.12	.18	.25	.32														
	2"	1.59 (50.8)	2.36 (2.36)	52012-A	U	592	379	263	193	148	117	95	78										
					D	.08	.13	.18	.25	.33	.42	.52	.63										
					C	466	466	386	331	290	257	232	211										
					D	.05	.10	.15	.20	.27	.34	.42	.51										
	2 1/2" (63.5)	1.67 (2.48)	2.48 (2.48)	52512-A	U	889	569	395	290	222	176	142	118	99	84	73	63						
					D	.07	.10	.15	.21	.28	.35	.43	.53	.63	.74	.85	.98						
					C	466	466	466	466	435	387	348	316	290	268	249	232						
					D	.02	.05	.10	.16	.22	.28	.35	.42	.50	.59	.68	.78						
3" (76.2)	1.75 (2.60)	2.60 (2.60)	53012-A	U	951	699	485	357	273	216	175	144	121	103	89	78	68						
				D	.05	.09	.14	.19	.25	.31	.39	.47	.56	.66	.77	.88	1.00						
				C	466	466	466	466	466	428	389	356	329	305	285	267							
				D	.02	.04	.07	.11	.17	.24	.31	.38	.45	.53	.61	.70	.80						
Alum. Alloy 5052 .100"	1 1/2" (38.1)	1.88 (2.79)	51510-A	U	459	294	204	150	115	91													
				D	.09	.15	.22	.30	.39	.50													
				C	450	360	300	257	225	200													
				D	.07	.12	.17	.24	.31	.40													
	2"	2.00 (50.8)	2.98 (2.98)	52010-A	U	829	530	368	271	207	164	133	110	92	78	68	59						
					D	.09	.14	.20	.28	.37	.46	.58	.70	.83	.98	1.13	1.30						
					C	714	649	541	464	406	361	325	295	270	250	232	216						
					D	.06	.11	.16	.22	.29	.37	.46	.56	.66	.78	.90	1.04						
	2 1/2" (63.5)	2.11 (3.14)	3.14 (3.14)	52510-A	U	1140	730	507	372	285	225	182	151	127	105	93	81	71					
					D	.07	.11	.16	.22	.28	.36	.45	.54	.64	.76	.88	1.01	1.15					
					C	714	714	714	638	558	496	446	406	372	343	319	298	279					
					D	.03	.07	.12	.17	.23	.29	.36	.43	.51	.60	.70	.81	.92					
3" (76.2)	2.22 (3.30)	3.30 (3.30)	53010-A	U	1458	942	654	481	368	291	235	195	164	139	120	105	92						
				D	.05	.08	.12	.17	.22	.28	.34	.42	.50	.59	.68	.78	.89						
				C	714	714	714	714	714	640	576	524	480	443	412	384	360						
				D	.02	.04	.07	.12	.17	.22	.27	.33	.40	.47	.54	.62	.71						

* Available on special order.

Engineering Data For Both Channels

Material Gauge	Channel Depth - in.	Sx in.²	Ix in.⁴	EI lb. x in.²
Steel 14 ga.	1 1/2"	.174	.102	2.96 x 10 ⁶
	2"	.270	.193	5.60 x 10 ⁶
	2 1/2"	.307	.335	9.71 x 10 ⁶
Steel 12 ga.	1 1/2"	.216	.125	3.62 x 10 ⁶
	2"	.342	.264	7.66 x 10 ⁶
	2 1/2"	.504	.488	14.09 x 10 ⁶
Aluminum .080"	3"	.625	.722	20.94 x 10 ⁶
	1 1/2"	.171	.137	1.40 x 10 ⁶
	2"	.251	.246	2.51 x 10 ⁶
Aluminum .100"	2 1/2"	.379	.441	4.50 x 10 ⁶
	3"	.464	.602	6.14 x 10 ⁶
	1 1/2"	.196	.156	1.59 x 10 ⁶
Aluminum 16 ga.	2"	.352	.309	3.15 x 10 ⁶
	2 1/2"	.486	.544	5.55 x 10 ⁶
	3"	.627	.911	9.29 x 10 ⁶
Stainless 304 16 ga.	2"	.165	.1425	4.13 x 10 ⁶
Stainless 316L 16 ga.	2"	.165	.1425	4.13 x 10 ⁶

Strut Loading

Material Gauge	Type Loading**	Load	Deflection in.
Steel 14 ga.	U	1444	.18
	Cs	707	.15
Steel 12 ga.	U	2277	.15
	Cs	1115	.12
Aluminum .080"	U	951	.24
	Cs	466	.20
Aluminum .100"	U	1458	.27
	Cs	714	.22
Stainless 304 16 ga.	U	947	.38
	Cs	464	.31
Stainless 316L 16 ga.	U	812	.31
	Cs	398	.25

** U = Allowable Uniform Load (lb./ft.²)
Cs = Allowable Concentrated Load per ft. of length at mid-width (lb./ft.)

Safe Loading Tables

8-Diamond Plank — 18³/₄" Width

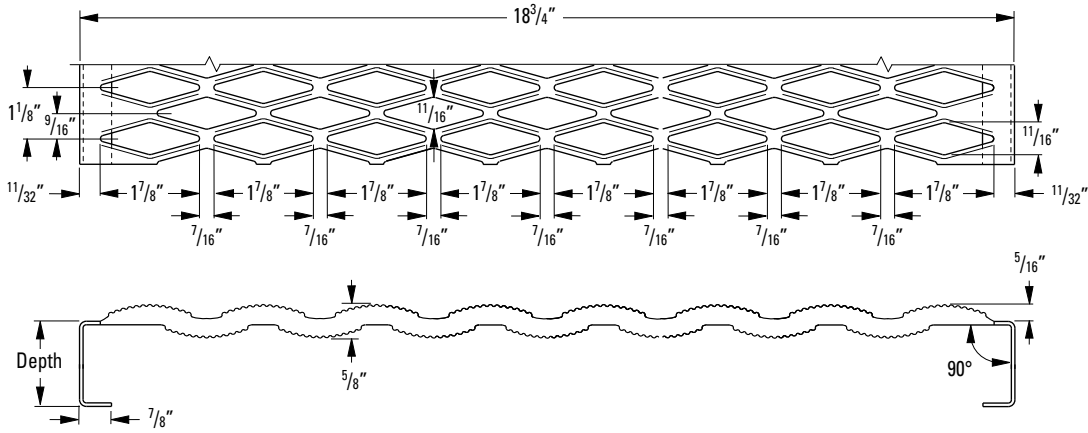

Product Selection/Design Tables

Allowable Loads and Deflections: U=Uniform Load (lb./ft.²) C= Concentrated Load (lb.) D=Deflection (in.)
Spans to the left of heavy red line produce a deflection of 1/4" or less under a uniform load of 100 lb./ft.²

Material Gauge	Channel Depth in. (mm)	Weight lb./lin. ft. (kg/m)	Catalog Number		Span																
					2'-0"	2'-6"	3'-0"	3'-6"	4'-0"	4'-6"	5'-0"	5'-6"	6'-0"	6'-6"	7'-0"	7'-6"	8'-0"	9'-0"	10'-0"	11'-0"	12'-0"
Steel 14 ga.	1 1/2" (38.1)	6.1 (9.1)	81514	U	337	217	151	112	86	69	56	47									
				D	.33	.27	.26	.29	.33	.38	.45	.55									
				C	263	211	178	153	135	121	110	101									
				D	.16	.15	.15	.16	.17	.19	.22	.25									
	2" (50.8)	6.3 (9.4)	82014	U	540	358	250	184	142	113	92	76	65	55	48	42					
				D	.48	.37	.34	.32	.34	.38	.43	.50	.58	.66	.77	.87					
				C	437	349	292	251	220	198	179	164	152	141	132	124					
				D	.24	.21	.20	.19	.20	.21	.23	.26	.29	.32	.36	.40					
	2 1/2" (63.5)	6.6 (9.8)	82514	U	540	411	286	211	162	129	105	87	74	63	56	48	43				
				D	.46	.39	.35	.28	.27	.28	.31	.35	.39	.44	.50	.57	.64				
				C	450	402	335	287	252	225	205	188	173	161	151	142	134				
				D	.24	.22	.20	.19	.19	.19	.20	.21	.23	.24	.27	.29	.32				
Steel 12 ga.	1 1/2" (38.1)	8.5 (12.6)	81512	U	446	287	201	148	115	91	75	63	53	46	40						
				D	.27	.22	.22	.26	.32	.39	.47	.56	.67	.80	.92						
				C	359	280	235	203	179	161	146	135	125	117	110						
				D	.12	.12	.12	.14	.16	.19	.22	.26	.30	.35	.40						
	2" (50.8)	8.9 (13.2)	82012	U	710	456	318	235	181	144	117	98	83	71	62	54	48				
				D	.31	.25	.23	.25	.28	.31	.37	.44	.51	.60	.68	.79	.90				
				C	554	444	371	319	282	253	229	210	194	181	169	160	151				
				D	.17	.15	.14	.15	.16	.17	.19	.22	.25	.28	.32	.36	.40				
	2 1/2" (63.5)	9.2 (13.7)	82512	U	810	680	473	348	267	212	172	143	120	103	89	78	69	55	45		
				D	.33	.31	.27	.26	.27	.29	.32	.37	.42	.49	.55	.63	.72	.90	1.12		
				C	800	663	553	475	416	371	334	307	282	262	244	229	216	194	177		
				D	.23	.20	.18	.18	.18	.18	.19	.21	.23	.25	.28	.31	.34	.41	.50		
3" (76.2)	9.6 (14.3)	83012	U	810	810	598	440	337	267	217	180	152	130	112	98	87	69	57	47	40	
			D	.32	.35	.30	.27	.26	.28	.31	.34	.39	.43	.49	.56	.62	.78	.96	1.17	1.40	
			C	800	800	699	600	526	468	422	385	353	327	307	288	271	243	221	203	189	
			D	.22	.23	.22	.20	.20	.20	.20	.21	.22	.24	.26	.28	.31	.37	.44	.52	.61	

Safe Loading Tables

8-Diamond Plank — 18³/₄" Width

Product Selection/Design Tables

Allowable Loads and Deflections: U=Uniform Load (lb./ft.) C= Concentrated Load (lb.) D=Deflection (in.)
Spans to the left of heavy red line produce a deflection of 1/4" or less under a uniform load of 100 lb./ft.²

Material Gauge	Channel Depth in. (mm)	Weight lb./lin. ft. (kg/m)	Catalog Number	Span																	
				2'-0"	2'-6"	3'-0"	3'-6"	4'-0"	4'-6"	5'-0"	5'-6"	6'-0"	6'-6"	7'-0"	7'-6"	8'-0"	9'-0"	10'-0"	11'-0"	12'-0"	
Alum. Alloy 5052 .080"	1 1/2"* (38.1)	2.11 (3.13)	81512-A	U	253	162	112	83													
				D	.49	.40	.39	.44													
				C	198	158	132	113													
				D	.24	.22	.22	.24													
	2"	2.20 (50.8)	82012-A	U	308	237	165	121	93	73	59	49									
				D	.54	.50	.44	.44	.47	.53	.61	.71									
				C	290	232	193	166	145	129	116	106									
				D	.32	.28	.27	.27	.28	.30	.32	.36									
	2 1/2"* (63.5)	2.29 (3.40)	82512-A	U	308	308	248	182	139	110	89	74	62	53							
				D	.51	.57	.54	.49	.50	.52	.57	.65	.73	.83							
				C	350	348	290	249	218	194	174	158	145	134							
				D	.37	.39	.35	.33	.33	.34	.35	.37	.40	.43							
3"* (76.2)	2.39 (3.55)	83012-A	U	308	308	308	223	171	135	109	90	76	65	56	49						
			D	.50	.54	.62	.54	.52	.52	.56	.61	.68	.76	.86	.96						
			C	350	350	350	306	268	238	214	195	178	165	153	143						
			D	.37	.38	.41	.38	.37	.37	.37	.39	.40	.43	.46	.50						
Alum. Alloy 5052 .100"	1 1/2"* (38.1)	2.68 (3.98)	81510-A	U	288	184	128	94	72	57											
				D	.41	.36	.36	.40	.47	.56											
				C	225	180	150	129	113	100											
				D	.18	.18	.19	.21	.23	.27											
	2"	2.79 (4.15)	82010-A	U	457	332	231	170	130	103	83	69	58	49							
				D	.59	.51	.46	.47	.52	.57	.67	.78	.89	1.03							
				C	406	325	271	232	203	181	163	148	135	125							
				D	.29	.26	.25	.26	.28	.30	.33	.37	.42	.47							
	2 1/2"* (63.5)	2.91 (4.33)	82510-A	U	457	457	317	233	179	141	114	94	79	68	58	51	45				
				D	.55	.62	.51	.48	.48	.52	.58	.64	.73	.84	.94	1.07	1.20				
				C	550	447	372	319	279	248	223	203	186	172	160	149	140				
				D	.37	.32	.30	.29	.29	.30	.32	.35	.38	.41	.46	.52	.55				
3"* (76.2)	3.02 (4.50)	83010-A	U	457	457	410	301	231	182	148	122	102	87	75	66	58					
			D	.53	.57	.58	.51	.48	.48	.51	.56	.61	.69	.76	.85	.95					
			C	550	550	481	412	360	320	288	262	240	222	206	192	180					
			D	.37	.39	.37	.35	.34	.34	.36	.38	.41	.44	.48	.52	.57					

* Available on special order.

Engineering Data For Both Channels

Material Gauge	Channel Depth in.	Sx in.²	Ix in.⁴	EI lb. x in.²
Steel 14 ga.	1 1/2"	.174	.102	2.96 x 10 ⁶
	2"	.270	.193	5.60 x 10 ⁶
	2 1/2"	.307	.335	9.71 x 10 ⁶
Steel 12 ga.	1 1/2"	.216	.125	3.62 x 10 ⁶
	2"	.342	.264	7.66 x 10 ⁶
	2 1/2"	.504	.488	14.09 x 10 ⁶
Aluminum .080"	3"	.625	.722	20.94 x 10 ⁶
	1 1/2"	.171	.137	1.40 x 10 ⁶
	2"	.251	.246	2.51 x 10 ⁶
Aluminum .100"	2 1/2"	.379	.441	4.50 x 10 ⁶
	3"	.464	.602	6.14 x 10 ⁶
	1 1/2"	.196	.156	1.59 x 10 ⁶
Aluminum .100"	2"	.352	.309	3.15 x 10 ⁶
	2 1/2"	.456	.544	5.55 x 10 ⁶
	3"	.627	.911	9.29 x 10 ⁶

Strut Loading

Material Gauge	Type Loading**	Load	Deflection in.
Steel 14 ga.	U	540	.43
	Cs	422	.35
Steel 12 ga.	U	810	.30
	Cs	633	.24
Aluminum .080"	U	308	.48
	Cs	241	.39
Aluminum .100"	U	457	.51
	Cs	357	.41

** U = Allowable Uniform Load (lb./ft.)
Cs = Allowable Concentrated Load per ft. of length at mid-width (lb./ft.)

Safe Loading Tables

10-Diamond Plank — 24" Width

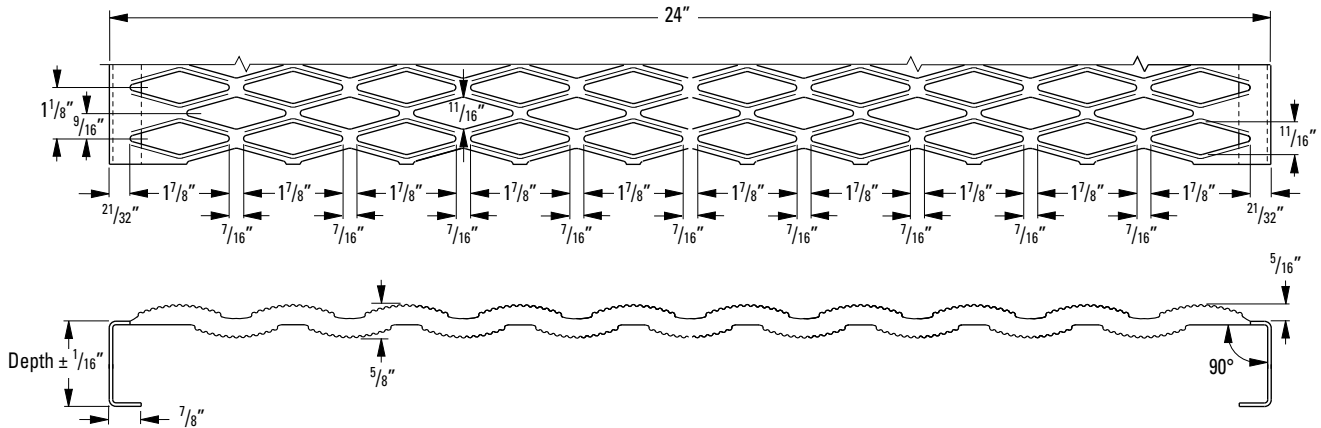

Product Selection/Design Tables

Allowable Loads and Deflections: U=Uniform Load (lb./ft.²) C= Concentrated Load (lb.) D=Deflection (in.)
Spans to the left of heavy red line produce a deflection of 1/4" or less under a uniform load of 100 lb./ft.²

Material Gauge	Channel Depth in. (mm)	Weight lb./in. ft (kg/m)	Catalog Number		Span															
					2'-0"	2'-6"	3'-0"	3'-6"	4'-0"	4'-6"	5'-0"	5'-6"	6'-0"	6'-6"	7'-0"	7'-6"	8'-0"	9'-0"	10'-0"	11'-0"
Steel 14 ga.	2" (50.8)	7.4 (11.0)	102014	U	300	300	228	168	128	102	82	68	57	49	42					
				D	.46	.48	.42	.38	.38	.41	.44	.49	.55	.62	.70					
				C	400	400	343	294	257	229	206	187	172	158	147					
	3" (76.2)	7.9 (11.8)	103014	U	300	300	300	264	202	160	130	107	90	77	66	58	51	40		
				D	.42	.43	.46	.44	.39	.36	.35	.36	.39	.44	.45	.49	.54	.65		
				C	400	400	400	400	400	360	324	295	270	249	232	216	203	180		
Steel 12 ga.	2" (50.8)	10.4 (15.5)	102012	U	475	416	289	212	162	128	104	86	72	62	53	46				
				D	.40	.39	.33	.31	.31	.34	.38	.44	.48	.56	.63	.71				
				C	650	520	434	372	325	289	260	237	217	200	186	174				
	3" (76.2)	11.1 (16.5)	103012	U	475	475	475	392	300	237	192	159	133	114	98	85	75	59	48	
				D	.38	.39	.42	.38	.36	.34	.35	.37	.39	.43	.47	.52	.58	.70	.85	
				C	900	900	800	686	600	534	480	437	400	369	343	320	300	267	240	
D	.34	.35	.33	.29	.27	.26	.26	.26	.26	.26	.27	.29	.30	.32	.36	.41				

Engineering Data For Both Channels

Material Gauge	Channel Depth in.	Sx in. ²	Ix in. ⁴	EI lb. x in. ²
Steel	2"	.303	.232	6.73 x 10 ⁶
14 ga.	3"	.484	.713	20.68 x 10 ⁶
Steel	2"	.387	.346	10.03 x 10 ⁶
12 ga.	3"	.715	.959	27.81 x 10 ⁶

Strut Loading

Material Gauge	Type Loading**	Load	Deflection in.
Steel	U	300	.49
14 ga.	Cs	300	.40
Steel	U	475	.45
12 ga.	Cs	475	.36

** U = Allowable Uniform Load (lb./ft.²)

Cs = Allowable Concentrated Load per ft. of length at mid-width (lb./ft.)

10-Diamond Walkway — 24" Width

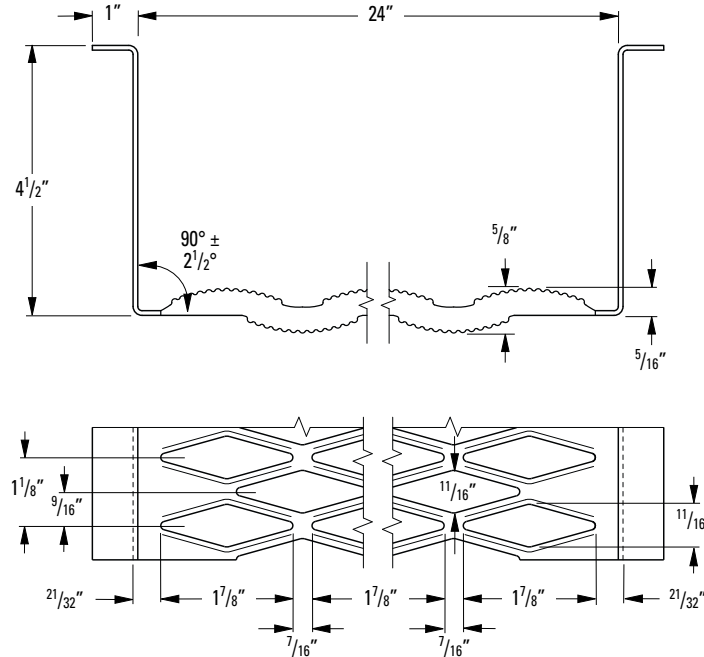

Product Selection/Design Tables

Allowable Loads and Deflections: U=Uniform Load (lb./ft.²) C= Concentrated Load (lb.) D=Deflection (in.)
Spans to the left of heavy red line produce a deflection of 1/4" or less under a uniform load of 100 lb./ft.²

Material Gauge	Weight lb./lin. ft. (kg/m)	Catalog Number		Span																
				2'-0"	2'-6"	3'-0"	3'-6"	4'-0"	4'-6"	5'-0"	5'-6"	6'-0"	6'-6"	7'-0"	7'-6"	8'-0"	9'-0"	10'-0"	11'-0"	12'-0"
Steel 14 ga	8.9 (13.2)	104514-U	U	300	300	300	300	300	263	213	176	148	126	109	95	83	66	53	43	
			D	.41	.41	.42	.45	.48	.47	.42	.40	.40	.41	.43	.45	.47	.55	.64	.75	
			C	400	400	400	400	400	400	400	400	400	400	400	400	380	355	333	296	266
Steel 12 ga	12.5 (18.6)	104512-U	U	475	475	475	475	475	420	340	281	236	201	173	151	133	105	85	70	59
			D	.37	.37	.38	.40	.43	.43	.39	.37	.37	.37	.39	.41	.44	.51	.59	.69	.80
			C	900	900	900	900	900	900	850	773	709	654	607	567	531	472	425	387	354
			D	.34	.34	.35	.35	.36	.37	.37	.35	.34	.33	.33	.33	.33	.35	.37	.40	.44

Engineering Data For Both Channels

Material Gauge	Channel Depth in.	Sx in.²	Ix in.⁴	EI lb. x in.²
Steel 14 ga.	4 1/2"	.806	1.43	41.47 x 10 ⁶
Steel 12 ga.	4 1/2"	1.290	2.42	10.03 x 10 ⁶

Strut Loading

Material Gauge	Type Loading**	Load	Deflection in.
Steel 14 ga.	U	300	.49
	Cs	300	.40
Steel 12 ga.	U	475	.45
	Cs	475	.36

** U = Allowable Uniform Load (lb./ft.²)

Cs = Allowable Concentrated Load per ft. of length at mid-width (lb./ft.)

Comparative Performance Tables

8-Diamond Plank — 18³/₄" Width

Note: The data in these tables represents the

performances of both side channels ignoring grating surface performance. These values are not to be used for product selection but should be used when comparisons are being made with other products whose published information does not include grating surface performance. For Product selection and Design Tables, see pages 6 through 17.

U=Uniform Load (lb./ft.) C= Concentrated Load (lb.) D=Deflection (in.)

Material Gauge	Channel Depth in. (mm)	Weight lb./lin. ft. (kg/m)	Catalog Number		Span																		
					2'-0"	2'-6"	3'-0"	3'-6"	4'-0"	4'-6"	5'-0"	5'-6"	6'-0"	6'-6"	7'-0"	7'-6"	8'-0"	9'-0"	10'-0"	11'-0"	12'-0"		
Steel 14 ga.	1 1/2" (38.1)	6.1 (9.1)	81514	U	337	217	151	112	86	69	56	47	40										
				D	.06	.10	.14	.20	.26	.33	.41	.51	.61										
				C	525	421	355	306	270	242	220	202	187										
				D	.05	.08	.12	.16	.21	.27	.33	.41	.49										
	2"	6.3 (9.4)	82014	U	557	358	250	184	142	113	92	76	65	55	48	42							
				D	.06	.09	.13	.17	.23	.29	.36	.44	.53	.62	.73	.84							
				C	873	698	583	501	440	396	358	328	303	281	264	248							
				D	.05	.07	.10	.14	.18	.23	.29	.35	.42	.50	.58	.67							
	2 1/2" (63.5)	6.6 (9.8)	82514	U	639	411	286	211	162	129	105	87	74	63	55	48	43						
				D	.04	.06	.08	.11	.14	.18	.23	.28	.33	.39	.46	.53	.61						
				C	1003	803	669	574	504	449	410	375	346	321	301	283	267						
				D	.03	.04	.06	.09	.12	.15	.18	.22	.27	.32	.37	.43	.49						
Steel 12 ga.	1 1/2" (38.1)	8.5 (12.6)	81512	U	446	287	201	148	115	91	75	63	53	46	40								
				D	.07	.11	.15	.21	.28	.36	.44	.54	.65	.78	.91								
				C	718	560	470	406	358	321	292	269	249	233	219								
				D	.06	.08	.12	.17	.22	.28	.35	.43	.52	.62	.73								
	2"	8.9 (13.2)	82012	U	710	456	318	235	181	144	117	98	83	71	62	54	48						
				D	.05	.08	.11	.16	.21	.26	.33	.40	.48	.57	.66	.77	.88						
				C	1107	887	741	637	564	505	458	419	387	361	338	319	302						
				D	.04	.06	.09	.12	.16	.21	.26	.32	.38	.45	.53	.61	.71						
	2 1/2" (63.5)	9.2 (13.7)	82512	U	1059	680	473	348	267	212	172	143	120	103	89	78	69	55	45				
				D	.04	.06	.09	.13	.17	.21	.26	.32	.38	.45	.52	.60	.69	.88	1.10				
				C	1656	1325	1106	949	832	741	668	613	564	523	488	458	431	388	353				
				D	.03	.05	.07	.10	.13	.17	.21	.26	.30	.36	.42	.48	.55	.71	.88				
3"	9.6 (14.3)	83012	U	1340	858	598	440	337	267	217	180	152	130	112	98	87	69	57	47	40			
			D	.04	.06	.08	.11	.14	.18	.23	.27	.33	.38	.45	.52	.59	.75	.94	1.15	1.39			
			C	2097	1678	1398	1200	1051	936	844	769	706	653	614	575	542	486	442	406	377			
			D	.03	.04	.06	.09	.11	.15	.18	.22	.26	.31	.36	.41	.47	.60	.75	.92	1.11			
Alum. Alloy 5052 .080"	1 1/2"* (38.1)	2.11 (3.13)	81512-A	U	253	162	112	83															
				D	.10	.15	.22	.31															
				C	395	316	263	226															
				D	.08	.12	.18	.25															
	2"	2.20 (3.27)	82012-A	U	371	237	165	121	93	73	59	49											
				D	.08	.13	.18	.25	.33	.42	.52	.63											
				C	579	463	386	331	290	257	232	211											
				D	.06	.10	.15	.20	.27	.34	.42	.51											
	2 1/2"* (63.5)	2.29 (3.40)	8251A	U	557	357	248	182	139	110	89	74	62	53	46								
				D	.07	.10	.15	.21	.28	.35	.43	.53	.63	.74	.85								
				C	812	696	580	497	435	387	348	316	290	268	249								
				D	.05	.08	.12	.17	.22	.28	.35	.42	.50	.59	.68								
3"* (76.2)	2.39 (3.55)	8301A	U	684	438	304	223	171	135	109	90	76	65	56	49								
			D	.06	.09	.14	.19	.25	.31	.39	.47	.56	.66	.77	.88								
			C	1069	856	713	611	535	475	428	389	356	329	305	285								
			D	.04	.07	.11	.15	.20	.25	.31	.38	.45	.53	.61	.70								
Alum. Alloy 5052 .100"	1 1/2"* (38.1)	2.68 (3.98)	81510-A	U	288	184	128	94	72	57													
				D	.09	.15	.22	.30	.39	.50													
				C	450	360	300	257	225	200													
				D	.07	.12	.17	.24	.31	.40													
	2"	2.79 (4.15)	82010-A	U	519	332	231	170	130	103	83	68	58	49									
				D	.09	.14	.20	.28	.37	.46	.58	.70	.83	.98									
				C	811	649	541	464	406	361	325	295	270	250									
				D	.07	.11	.16	.22	.29	.46	.56	.66	.78										
	2 1/2"* (63.5)	2.91 (4.33)	82510-A	U	714	457	317	233	179	141	114	94	79	68	58	51	45	40					
				D	.07	.11	.16	.22	.28	.36	.45	.54	.64	.76	.88	1.01	1.15	1.30					
				C	1116	893	744	638	558	496	446	406	373	343	319	298	279	263					
				D	.05	.09	.12	.17	.23	.29	.36	.43	.51	.60	.70	.81	.92	1.04					
3"* (76.2)	3.02 (4.50)	83010-A	U	922	590	410	301	231	182	148	122	102	87	75	66	58	51	46					
			D	.05	.08	.12	.17	.22	.28	.34	.42	.50	.59	.68	.78	.89	1.01	1.13					
			C	1441	1153	961	823	720	640	576	524	480	443	412	384	360	339	320					
			D	.04	.06	.10	.13	.17	.22	.27	.33	.40	.47	.54	.62	.71	.80	.90					

* Available on special order.

Comparative Performance Tables

10-Diamond Plank & Walkway 24" Width

Note

The data in these tables represents the performances of both side channels ignoring grating surface performance. These values are not to be used for product selection but should be used when comparisons are being made with other products whose published information does not include grating surface performance.

For Product selection and Design Tables, see pages 6 through 17.

U=Uniform Load (lb./ft.²) C= Concentrated Load (lb.) D=Deflection (in.)

Material Gauge	Channel Depth in. (mm)	Weight lb./lin. ft. (kg/m)	Catalog Number	Span																				
				2'-0"	2'-6"	3'-0"	3'-6"	4'-0"	4'-6"	5'-0"	5'-6"	6'-0"	6'-6"	7'-0"	7'-6"	8'-0"	9'-0"	10'-0"	11'-0"	12'-0"				
Steel 14 ga. Plank	2" (50.8)	7.4 (11.0)	102014	U	514	329	228	168	128	102	82	68	57	49										
				D	.05	.08	.12	.16	.21	.27	.33	.40	.47	.55										
				C	1028	822	685	587	514	457	411	374	343	316	294	274	257	228	206	187	171			
	3" (76.2)	7.9 (11.8)	103014	U	810	518	360	264	202	160	130	107	90	77	66	58	51							
				D	.03	.05	.07	.09	.12	.15	.18	.22	.27	.31	.36	.41	.47							
				C	1620	1296	1080	926	810	720	648	589	540	498	463	432	405	360	324	295	270			
Steel 12 ga. Plank	2" (50.8)	10.4 (15.5)	102012	U	650	416	289	212	162	128	104	86	72	62	53									
				D	.07	.08	.11	.15	.19	.24	.30	.37	.43	.51	.59									
				C	1300	1040	867	743	650	578	520	473	433	400	371	347	325	289	260	236	217			
	3" (76.2)	11.1 (16.5)	103012	U	1200	768	533	392	300	237	192	159	133	114	98	85	75	59						
				D	.03	.05	.07	.10	.13	.16	.20	.25	.29	.34	.40	.46	.52	.66						
				C	2400	1920	1600	1371	1200	1067	960	873	800	736	686	640	600	533	480	436	400			
Steel 14 ga. Walkway	4.5" (114.3)	8.9 (13.2)	104514-U	U	1330	851	591	434	332	263	213	176	148	126	109	95	83	66	53					
				D	.02	.04	.05	.07	.09	.12	.14	.17	.20	.24	.28	.32	.36	.46	.57					
				C	2660	2128	1773	1520	1339	1182	1064	967	887	818	760	709	665	591	532	484	443			
Steel 12 ga. Walkway	4.5" (114.3)	12.5 (18.6)	104512-U	U	2125	1360	944	694	531	420	340	281	236	201	173	151	133	105	85	70	59			
				D	.02	.03	.05	.06	.08	.11	.13	.16	.19	.22	.26	.30	.34	.43	.53	.64	.76			
				C	4200	3400	2833	2429	2125	1889	1700	1545	1417	1308	1214	1133	1062	944	850	773	708			
				D	.02	.03	.04	.05	.07	.09	.11	.13	.15	.18	.21	.24	.27	.34	.42	.51	.61			

Load/Deflection Conversion Formulas

In the elastic range, deflection is proportional to the applied load for both uniform and concentrated loads. This relationship can be used to determine the deflection that any load which is less than the allowable load will produce, as shown in Example A. Also, if desired, the load which will produce a specific deflection can also be determined if the load is in the elastic range as illustrated in Example B.

Example A

What deflection will a 300 lb. concentrated load produce on a plank (catalog number 103012) spanning 5'-0"?

See page 16 for item 103012 at a span = 5'-0" C = 480 lb. D = 0.26"
D @ 300 lb. = 0.26"/480 lb. x 300 lb. = 0.16"

Example B

If a plank (catalog number 103012) is spanning 6'-0", what concentrated load will produce a 1/4" deflection?

See page 16 for item 103012 at a span = 6'-0" C = 400 lb. D = 0.26"
C @ 1/4" = 400 lb./0.26" x 0.25" = 385 lb.

Fastening Anchors Accessories

Diamond Washer



Field drilling is required.

Part Number Includes

(1) Diamond Washer

Order Separately

(1) 5/16"-18 Carriage Bolt **

(1) 5/16" Flat Washer

(1) 5/16"-18 Hex Nut

Finish: G-90 mill galvanized
Also available in 304 stainless steel

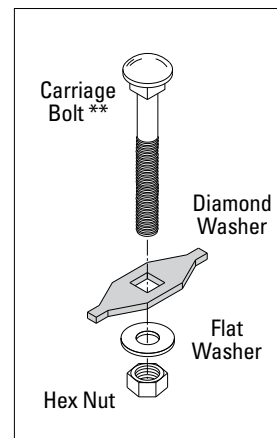

** Plank carriage bolt lengths = Side Channel Height + 1"
Walkway carriage bolt = 5/16"-18 x 2"

Diamond Washer

UPC Number	Catalog Number	Wt./Ea.
66251626610	12262	0.03

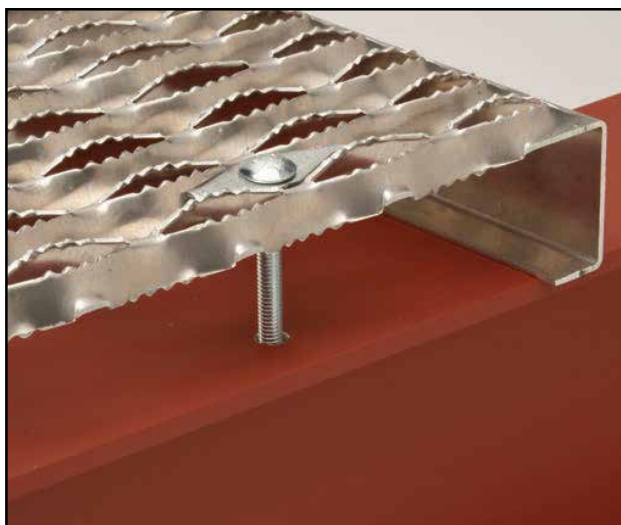

Assembly

1. Align GRIP STRUT planks on I-Beam or other anchoring cross-member.
2. Mark the I-Beam for drilling purposes under a slot near the end of GRIP STRUT plank. Drill a pilot hole.
3. Remove GRIP STRUT plank and drill a finish hole.
4. Replace GRIP STRUT plank. Align diamond washer over the drilled hole. Run the carriage bolt through the diamond washer and I-Beam. Tighten the washer and nut until secure.
5. Test for movement or slippage. If GRIP STRUT planks are not secure, check fastening system for loose or missing parts. Repeat steps 1 thru 4.

Note: Do not walk on GRIP STRUT planks if they are not secure. Serious injury could result.



Welding

A common method of fastening safety grating is welding. It is recommended that all B-Line Safety Grating products be fillet welded per AWS D1.3. For more information, consult Technical Services.

Fastening Anchor Accessories

Anchor Plate

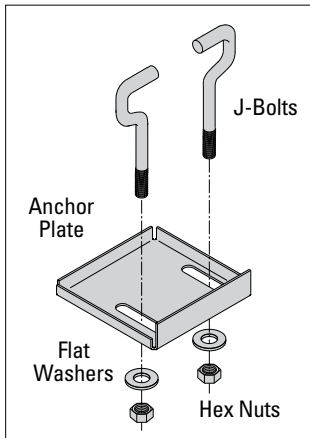

Finish: G-90
mill galvanized
Also available in 304
stainless steel

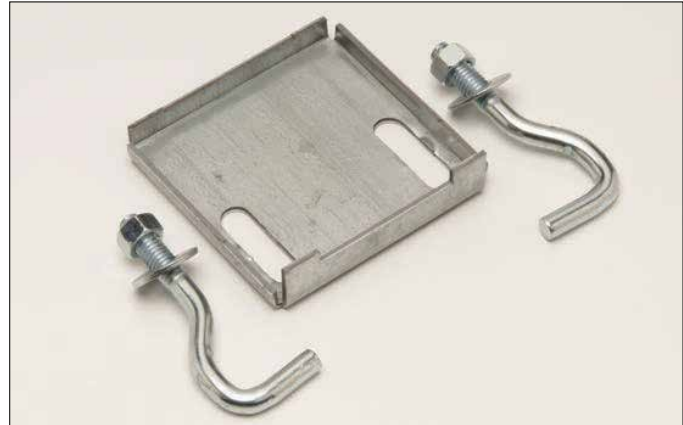

No field drilling is required.

Part Number Includes

- (1) Anchor Plate
- (2) 3/8" -16 J-Bolts
- (2) 3/8" Flat Washer
- (2) 3/8" -16 Hex Nut

Anchor Plate Assemblies *

UPC Number	Catalog Number	Grating Height	J-Bolt Size	Wt./Ea.
66251634139	ACA15	1 1/2"	3/8" -16 x 1 1/2"	0.80
66251634141	ACA20	2"	3/8" -16 x 2"	0.80
66251634142	ACA25	2 1/2"	3/8" -16 x 2 1/2"	0.80
66251634144	ACA30	3"	3/8" -16 x 3"	0.90

Assembly

1. Align two (2) GRIP STRUT planks side-by-side on I-Beam or other anchoring cross-member.
2. Place J-bolts in GRIP STRUT openings opposite each other. Make sure you choose the openings nearest to the inner edge of the plank.
3. Slide ACA anchor plate up J-bolts until snug. Make sure the inside edge of the ACA anchor plate is as close as possible to the center of the cross member.
4. Tighten nuts until planks are secured.
5. Test for movement or slippage. If GRIP STRUT planks are not secure, check fastening system for loose or missing parts. Repeat steps 1 thru 4.

Note: Do not walk on GRIP STRUT planks if they are not secure. Serious injury could result.



Welding

A common method of fastening safety grating is welding. It is recommended that all B-Line Safety Grating products be fillet welded per AWS D1.3. For more information, consult Technical Services.



Walkway Accessories

Walkway Splice Plate (30" Long) Kit

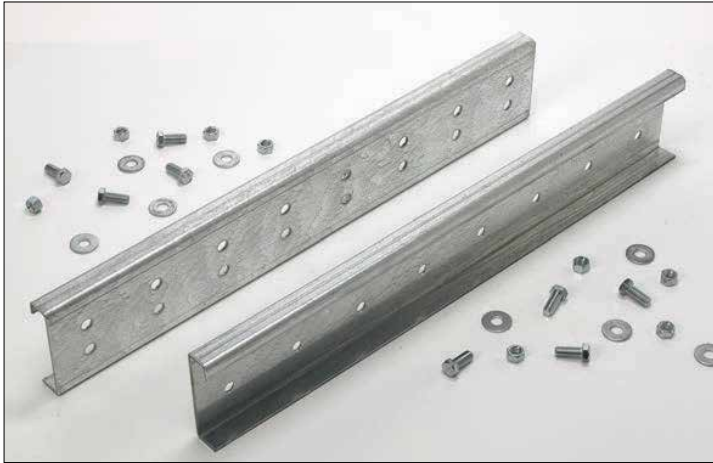

Part Number Includes

- (2) Splice Plates
- (32) 1/2"-13 x 1 1/4" Hex Bolts
- (32) 1/2"-13 Hex Nuts
- (32) 1/2" Washers

Walkway Splice Plate Kit

UPC Number	Catalog Number	Wt./Ea.
66251642714	SP-10DU-30	18.1

Walkway splice plates provide continuity when multiple lengths of GRIP STRUT™ walkway are desired. Connections are reinforced with the addition of splice plates attached to side channels.

Splice plates are formed from 12 gauge mill-galvanized steel, prepunched and supplied with hardware shown above.

Torque to 40 ft.-lbs.

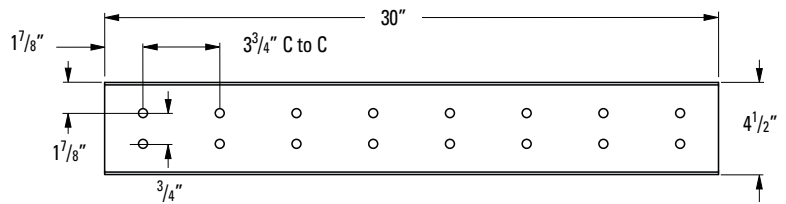

Walkway Splice Plate (7" Long) Kit



Part Number Includes

- (2) Splice Plates - 4" x 7"
- (16) 7/16"-14 x 1 1/4" Hex Bolts
- (16) 7/16"-14 Hex Nuts
- (16) 7/16" Washers

Kit joins continuous sections together in a run only over supports.

Note: Contact factory for information on pre-punched holes in walkway grating.

Splice plates are formed from 10 gauge mill-galvanized steel, prepunched and supplied with hardware shown above.

Torque to 55 ft.-lbs. (minimum)

Walkway Splice Plate Kit

UPC Number	Catalog Number	Wt./Ea.
66251642716	SP-10DU-7	4.1



Special & Fabricated Products

Reconditioning Material

Here's the "safety first" way to re-do worn and unsafe floors and stairs - resurface with non-slip GRIP STRUT™ safety grating reconditioning material (RM). GRIP STRUT safety grating is the only product that gives 500 wall-to-wall teeth per square foot. Serrated, diamond-shaped openings make GRIP STRUT safety grating safer than conventional gratings — permit mud, oil, grease and industrial waste to fall through, when used over open floor materials such as bar grating. Even ice shears free under normal foot pressure. Down-turned edges allow grating to lie flat and secure over existing flooring. Consult distributor for product specifications.

Other important GRIP STRUT safety grating advantages include: easy field fabrication and fast, low-cost installation. RM products available on special order in standard materials and sizes.

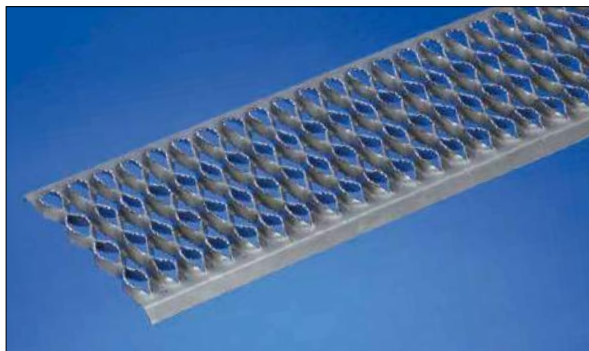

Reconditioning Material

Flat Stock Material

Flat Stock can be manufactured to specified dimensions of flat metal on either or both sides. Consult your distributor for specifications and availability.

Versatility in form and function for new or special products

Because of its light-weight plank design, GRIP STRUT safety grating is easy to handle and economical to install. Most sections can be handled by one man. Simply and quickly field-cut with standard tools. Layout and erection goes quickly because panels match perfectly. Various widths may be used to suit space requirements.

Many variations of GRIP STRUT safety grating panels are available to suit specific requirements. Special forming can be accomplished to suit requirements not covered by the standard panels. Consult your distributor for availability.

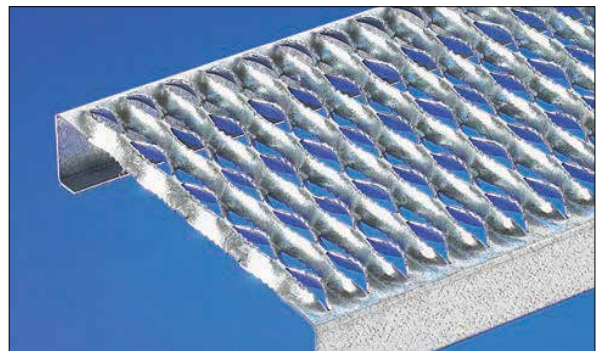

GRIP STRUT with Standard Serrated Surface

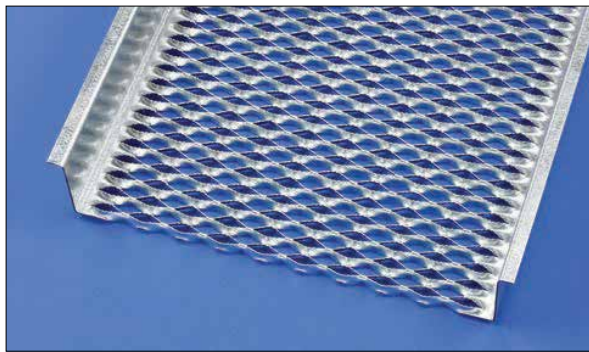

GRIP STRUT Walkways



GRIP STRUT with Non-Serrated Surface

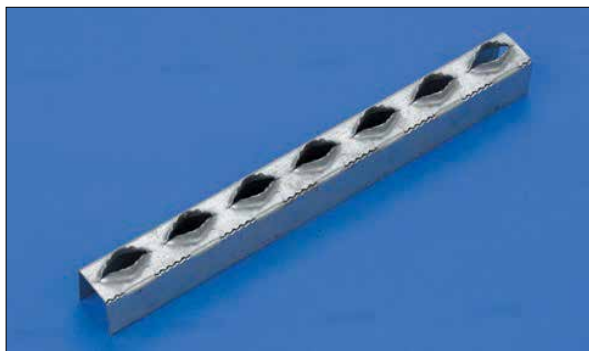

GRIP STRUT 1-diamond rungs

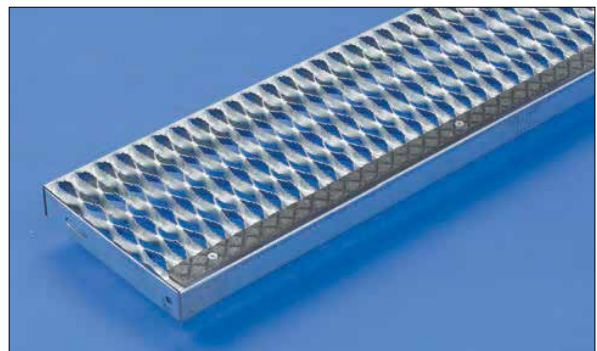

GRIP STRUT Stair Treads

Special & Fabricated Products

Fabricating Services

We can quote large jobs on a lump-sum basis, including detailing and fabricating of special material, to your requirements. Submit plans and specifications through your GRIP STRUT™ safety grating distributor.

After your order is received, a bill of materials and shop drawings will be prepared for your approval before fabrication is begun. A few of the fabricating services available include: special cutting, marking according to layout, banding and toe plates.

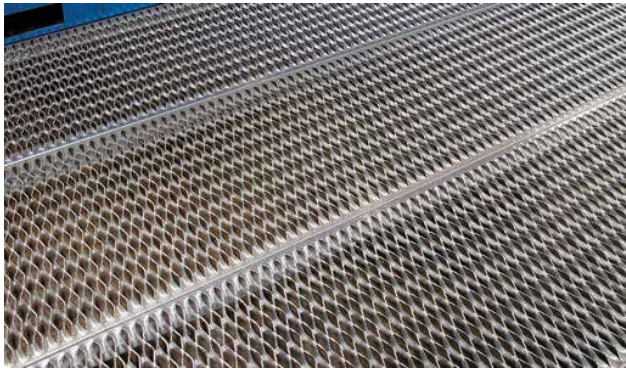

GRIP STRUT Flooring

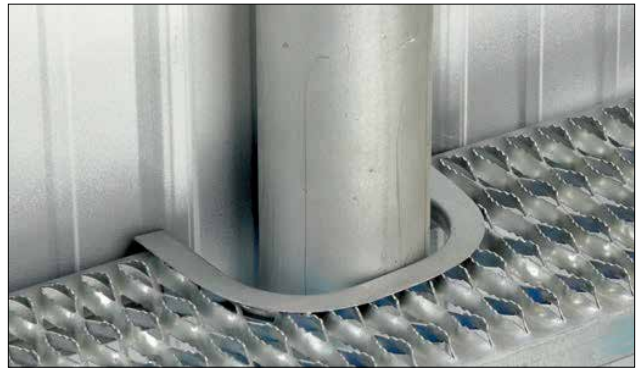

GRIP STRUT Special Fabrication



Special Walkways



GRIP STRUT - Railcar Walkways



Industrial Walkways



GRIP STRUT Stairs & Ramps

Stair Tread Information

Safe Loading — Stair Treads

Load data below takes eccentric loads into consideration. Although load values include allowances for normal impact conditions and usual pedestrian traffic, be sure to make provisions in the structural design for special uses and loads involving unusual impact forces or vibratory forces. Load-carrying capacity of stair treads increases as side channel height and gauge or material increase.



Stair Tread Application



GRIP STRUT Stair Tread

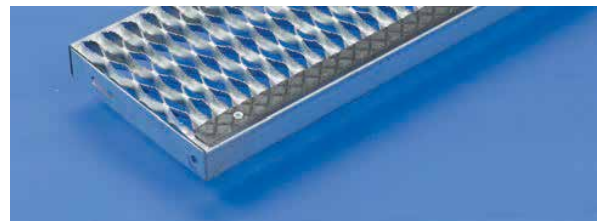

GRIP STRUT Stair Tread with Abrasive Nosing

U=Uniform Load (lb./ft.²) C= Concentrated Load (lb.)

Material	Gauge	2-Diamond 4/4" Depth				3-Diamond 7" Depth				4-Diamond 9/2" Depth				5-Diamond 11/4" Depth			
		Steel		Steel		Steel		Steel		Steel		Steel		Steel			
		14	12	14	12	14	12	14	12	14	12	14	12				
Span	Channel Depth - in. (mm)	U	C	U	C	U	C	U	C	U	C	U	C	U	C		
2'-0"	1 1/2" (38.1)	1191	472	1576	624	761	443	1006	587	549	435	750	595	434	425	575	563
	2" (50.8)	1978	783	2513	995	1262	737	1604	936	911	604	1158	917	721	573	916	897
2'-6"	1 1/2" (38.1)	764	378	1011	500	488	356	645	470	353	349	481	476	278	342	369	452
	2" (50.8)	1268	611	1611	797	810	590	1029	750	584	578	742	734	463	566	587	719
3'-0"	1 1/2" (38.1)	532	315	703	418	340	300	450	393	245	300	335	398	194	300	258	378
	2" (50.8)	882	524	1121	665	563	492	716	626	407	483	517	614	322	473	409	601
4'-0" (1)	2" (50.8)	498	394	633	501	318	372	404	472	230	364	292	463	182	356	232	454

(1) Intermediate stringer is recommended for spans over 4 feet.

Material	Gauge	2-Diamond 4/4" Depth				3-Diamond 7" Depth				4-Diamond 9/2" Depth				5-Diamond 11/4" Depth											
		Aluminum		Aluminum		Aluminum		Stainless Steel		Aluminum		Stainless Steel													
		.080"	.100"	.080"	.100"	.080"	.100"	304	316L	.080"	.100"	304	316L												
Span	Channel Depth in. (mm)	U	C	U	C	U	C	U	C	U	C	U	C	U	C										
2'-0"	2" (50.8)	1328	526	1862	737	862	503	1208	705	607	481	867	687	610	483	525	416	396	388	607	595	394	386	338	331
2'-6"	2" (50.8)	850	420	1191	590	551	402	773	564	388	392	555	550	390	387	336	336	253	388	388	540	252	381	216	339
3'-0"	2" (50.8)	590	350	827	491	383	335	537	470	270	327	385	458	271	323	233	279	176	321	270	450	175	319	150	275
4'-0" (1)	2" (50.8)	332	263	465	369	215	252	302	353	152	245	216	344	152	244	131	210	99	241	151	338	98	241	84	221

(1) Intermediate stringer is recommended for spans over 4 feet.

Stair Tread Information

Standard Sizes and Recommended Spans ⁽¹⁾

Steel		Standard Stair Treads			Stair Treads with Abrasive Nosing		
Span in.	Gauge	Channel Depth - in.	Catalog Number	Size in.	Catalog Number	Size in.	
Up to 30"	14	1 1/2"	T-21514	2-Diamond - 4 ³ / ₄ "	--	--	
			T-31514	3-Diamond - 7"	T-31514-N	3-Diamond - 8 ¹ / ₈ "	
			T-41514	4-Diamond - 9 ¹ / ₂ "	T-41514-N	4-Diamond - 10 ¹ / ₂ "	
			T-51514	5-Diamond - 11 ³ / ₄ "	--	--	
30" to 36"	14	1 1/2"	T-21514	2-Diamond - 4 ³ / ₄ "	--	--	
			T-31514	3-Diamond - 7"	T-31514-N	3-Diamond - 8 ¹ / ₈ "	
			T-41514	4-Diamond - 9 ¹ / ₂ "	T-41514-N	4-Diamond - 10 ¹ / ₂ "	
			T-51514	5-Diamond - 11 ³ / ₄ "	--	--	
36" to 42"	14 ga.	1 1/2"	T-21514	2-Diamond - 4 ³ / ₄ "	--	--	
			T-31514	3-Diamond - 7"	T-31514-N	3-Diamond - 8 ¹ / ₈ "	
			T-41514	4-Diamond - 9 ¹ / ₂ "	T-41514-N	4-Diamond - 10 ¹ / ₂ "	
			T-51514	5-Diamond - 11 ³ / ₄ "	--	--	
42" to 48"	14 ga.	2"	T-21514	2-Diamond - 4 ³ / ₄ "	--	--	
			T-31514	3-Diamond - 7"	T-31514-N	3-Diamond - 8 ¹ / ₈ "	
			T-41514	4-Diamond - 9 ¹ / ₂ "	T-41514-N	4-Diamond - 10 ¹ / ₂ "	
			T-51514	5-Diamond - 11 ³ / ₄ "	--	--	
Aluminum							
Up to 42"	.080"	2"	T-22012-A	2-Diamond - 4 ³ / ₄ "	--	--	
			T-32012-A	3-Diamond - 7"	T-32012-A-N	3-Diamond - 8 ¹ / ₈ "	
			T-42012-A	4-Diamond - 9 ¹ / ₂ "	T-42012-A-N	4-Diamond - 10 ¹ / ₂ "	
			T-52012-A	5-Diamond - 11 ³ / ₄ "	--	--	
Up to 48"	.100"	2"	T-22010-A*	2-Diamond - 4 ³ / ₄ "	--	--	
			T-32010-A*	3-Diamond - 7"	T-32010-A-N	3-Diamond - 8 ¹ / ₈ "	
			T-42010-A*	4-Diamond - 9 ¹ / ₂ "	T-42010-A-N	4-Diamond - 10 ¹ / ₂ "	
			T-52010-A*	5-Diamond - 11 ³ / ₄ "	--	--	
Stainless Steel							
Up to 30"	Type 316L 16 ga.	2"	T-42016-SL	4-Diamond - 9 ¹ / ₂ "	--	--	
			T-52016-SL	5-Diamond - 11 ³ / ₄ "	--	--	
Up to 36"	Type 304 16 ga.	2"	T-42012-A	4-Diamond - 9 ¹ / ₂ "	--	--	
			T-52012-A	5-Diamond - 11 ³ / ₄ "	--	--	

(1) Recommendations are based on approximate minimum loads of 300 lbs. concentrated; 100 lbs. uniform. Specific performance criteria may vary by municipality/building code body and should be locally checked prior to finalizing specifications.

* Available on special order.

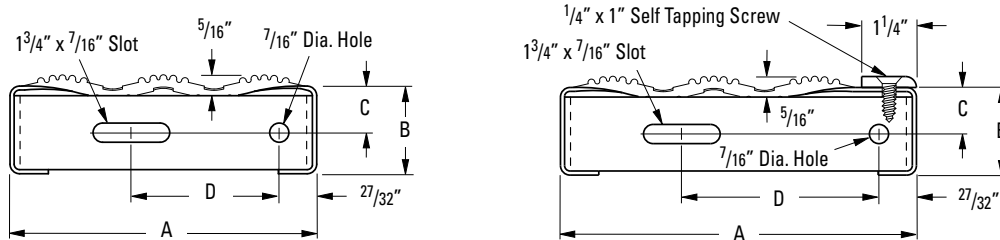

Steel, Aluminum and Stainless Steel ⁽¹⁾

Standard				With Abrasive Nosing			
A	B	C	D	A	B	C	D
4 ³ / ₄ " (2-Diamond)	1 1/2" 2"	3/4" 1"	2 ⁵ / ₈ " 2 ⁵ / ₈ "	--	--	--	--
7" (3-Diamond)	1 1/2" 2"	3/4" 1"	3 ³ / ₈ " 3 ³ / ₈ "	8 ¹ / ₈ " (3-Diamond)	1 1/2" 2"	3/4" 1"	4 1/2" 4 1/2"
9 1/2" (4-Diamond)	1 1/2" 2"	3/4" 1"	5 ⁷ / ₈ " 5 ⁷ / ₈ "	10 1/2" (4-Diamond)	1 1/2" 2"	3/4" 1"	6 ⁷ / ₈ " 6 ⁷ / ₈ "
11 ³ / ₄ " (5-Diamond)	1 1/2" 2"	3/4" 1"	8 ¹ / ₈ " 8 ¹ / ₈ "	--	--	--	--

(1) Stainless Steel not available in 2-Diamond or 3-Diamond widths.

Specifications

Product Guide Specification

Specifier Notes: This product guide specification is written according to the Construction Specifications Institute (CSI) MasterFormat, Three-Part SectionFormat, and PageFormat, contained in the CSI Manual of Practice. Six-digit section numbers are from the MasterFormat, 2004 Edition.

The section must be carefully reviewed and edited by the Engineer to meet the requirements of the project and local building code. Coordinate with other specification sections and the drawings.

Specifier Notes: This section covers Eaton's B-Line Business' slip resistant, GRIP STRUT™ safety grating, grating planks, walkways, treads, ladder rungs and specialty items designed for industrial and commercial walking/working surfaces are included.

SECTION 05 53 00, Metal Gratings (05120) Safety Grating, Slip Resistant Walkways, Platforms and Treads

Part 1- General

1.1 Section Includes

- A. Safety Grating walkways, planks, stair-treads with reticulated and formed metal cross struts.
- B. Regular and Heavy Duty Safety Grating products constructed from single-sheet with integrally-formed channels at the edges.
- C. Slip resistant walkways, planks and stair-treads with stamped surface textures/patterns.

1.2 Related Documents & Sections

Drawings and general provisions of the contract, including General and Supplementary Conditions and Division 01 Specification Sections, apply to this section. Other related sections include:

- A. 05 51 00, Metal Stairs
 - 05 51 19, Metal Grating Stairs
 - 05 51 13, Metal Ladders
 - 05 51 36, Catwalks
- B. 05 55 00, Metals Stair Treads and Nosings

1.3 Submittals

- A. Submit drawings of Safety Grating products, accessories and attachments.
- B. Submit manufacturer's product data on Safety Grating products including, but not limited to; types, materials, finishes, gauge thickness, surface patterns. For each grating cross-section, submit dimensional information, span, load capacity and deflection requirements.
- C. Shop Drawings:
 - 1. Show fabrication and installation details, including plans.
 - 2. Coordination of drawings: Floor plans and sections, drawn to scale. Include scaled layout and relationships between grating and adjacent structural elements.

1.4 References

- A. ASTM A 123 - Standard Specification for Zinc (Hot-Dip Galvanized) Coatings on Iron and Steel Products
- B. ASTM A 240 - Standard Specification for Chromium and Chromium-Nickel Stainless Steel Plate, Sheet, and Strip for Pressure Vessels and for General Applications
- C. ASTM A 653 - Standard Specification for Steel Sheet, Zinc-Coated (Galvanized) or Zinc-Iron Alloy-Coated (Galvannealed) by the Hot-Dip Process
- D. ASTM A 924 - Standard Specification for General Requirements for Steel Sheet, Metallic Coated by the Hot-Dip Process
- E. ASTM A 1011 - Standard Specification for Steel, Sheet and Strip, Hot-Rolled, Carbon, Structural, High-Strength Low-Alloy, and High-Strength Low-Alloy with Improved Formability
- F. ASTM B 209 - Standard Specification for Aluminum and Aluminum-Alloy Sheet and Plate
- G. OSHA-Occupational Safety and Health Administration- Standards for walking-working surfaces. Part Number 1910, Subpart D.
- H. RR-G-1602D- Federal Specification For Safety Grating (other than bar type & excluding naval vessels)
- I. ISO 9001:2000 Quality Management System- Requirements.

1.5 Quality Assurance

- A. Manufacturers: Firms regularly engaged in the manufacture of safety grating of the types required, whose products have been in satisfactory use in similar service for not less than 5 years.
- B. OSHA Compliance: All grating installations must comply with OSHA Standards for walking working surfaces.
- C. Federal Specification RR-G-1602D (or current revision) defines the criteria for items to be considered "safety grating". Slip resistant performance data must be available to support compliance.
- D. Manufacturer must have an ISO registered quality system in place, and Manual available upon request.

1.6 Delivery, Storage and Handling

- A. Deliver safety grating and components carefully to avoid damage, denting and scoring of finishes. Do not install damaged material.
- B. Store materials in original packaging and in clean, dry space; protect from weather and construction traffic. Materials to be elevated off of ground by blocks or skids or pallets.

Part 2 Products

2.1 Acceptable Manufacturers

Safety Gratings: Subject to compliance with these specifications, safety gratings shall be installed as manufactured by B-Line GRIP Strut safety grating (or engineer approved equal).

2.2 Materials and Finish

- A. Hot Rolled, Pickled & Oiled Steel: Commercial steel per ASTM A 1011, minimum yield of 33 ksi.
- B. Mill Galvanized Steel: Commercial steel per ASTM A 653 and ASTM A 924 with G-90 coating designation, minimum yield of 33 ksi.
- C. Hot-Dip Galvanized After Fabrication: Commercial steel per ASTM A 1011, minimum yield of 33 ksi, hot-dip galvanized after fabrication per ASTM A 123.
- D. Aluminum: Alloy 5052, Temper H32 aluminum per ASTM B 209
- E. Stainless Steel: Type 304 (Type 316) stainless steel, 2B or 2D finish, per ASTM A 240.

2.3 Gratings and Components

Safety Grating: (planks)(walkways)(treads)(ladder rungs) shall meet or exceed the Federal Standard RR-G-1602D for Safety Grating.

Part 3 Execution

3.1 Installation

- A. Inspect areas to receive grating for obstacles. Notify the Engineer of conditions that would adversely affect the installation or subsequent utilization of the areas. Do not proceed with installation until unsatisfactory conditions are corrected.
- B. Install grating according to manufacturer's recommendations and as shown on the construction drawings.
- C. Position grating sections flat and square with ends bearing minimum 1¹/₂" on supporting structure.
- D. Keep sections at least 1¹/₄" away from vertical steel sections and 1¹/₂" from concrete walls.
- E. Allow clearance at joints between sections of maximum 1¹/₂" at side channels and maximum 3³/₈" at ends.
- F. Band random cut ends and diagonal or circular cut exposed edges with a minimum 1¹/₈" thick bar welded at contact points.
- G. Join abutting walkway sections with manufacturer supplied splice plates; bolted or welded as specified.
- H. For stair treads, intermediate stringer is recommended for spans over 4 feet.

END OF SECTION

How To Order

GRIP STRUT™ safety grating and Stair Treads are stocked in all major markets. For the finest in Safety Grating and Stair Treads, contact us or look for your local GRIP STRUT distributor on the internet using www.bline.com.

Catalog number code

The catalog number code given below will assist you in ordering the material according to the specifications required.

1. Steel:

First numeral is width. "5" denotes 5-diamond or 1³/₄" width.

Second and third numerals denote channel size. "20" denotes 2", "15" denotes 1¹/₂", etc.

Last two numbers denote gauge. "12" denotes 12 gauge, "14" denotes 14 gauge.

Standard material is mill galvanized G-90 (ASTM A653)

Example: 52014 = 5-Diamond, 1³/₄" wide, 2" channel, 14 gauge

2. Aluminum:

First numeral is width. "5" denotes 5-diamond or 1³/₄" width.

Second and third numerals denote channel size. "20" denotes 2", "15" denotes 1¹/₂", etc.

Last two numbers denote gauge. "10" denotes .100" thick, "12" denotes .080" thick.

Material -A: Denotes aluminum.

Example: 52012-A = 5-Diamond, 1³/₄" wide, 2" channel, .080 thick, aluminum

3. Stainless Steel:

First numeral is width. "5" denotes 5-diamond or 1³/₄" width.

Second and third numerals denote channel size. "20" denotes 2", "15" denotes 1¹/₂", etc.

Last two numbers denote gauge. "16" denotes 16 gauge.

Material - S = Type 304, SL = 316L

Example: 52016-S = 5-Diamond, 1³/₄" wide, 2" channel, 16 gauge, Type 304 stainless

4. Stair Treads:

Any of the above numbers preceded by "T-"

Example: T-42014 = 4-Diamond, 9¹/₂" wide, 2" channel, 14 gauge, steel stair tread

5. Plain:

For ordering purposes, any catalog number followed by "B" signifies plain unpainted steel (HRP&O).

Example: 52012-B = 5-Diamond, 1³/₄" wide, 2" channel, 12 gauge, plain steel

6. Special Products:

Consult local GRIP STRUT safety grating distributor for identification and order placement of special products not herein identified.

Standard Sizes:

Length: (nominal 10'-0" and 12'-0")

Tolerances:

Planks: Standard 10'-0" and 12'-0" lengths are 120" and 144" respectively, with a tolerance of -0" +¹/₄".

Special lengths are available.

Treads: Standard stair tread lengths are as shown in this catalog with tolerances of ± ¹/₈".

Raw Materials:

Finishes:

A) Steel:

1) Pre-galvanized - ASTM A525

2) 14 gauge: hot rolled, commercial quality, oiled black steel and commercial quality, commercial coating, chemically treated galvanized steel

3) 12 gauge: hot rolled, pickled and oiled, commercial quality black steel and commercial quality, commercial coating, chemically treated galvanized steel

B) Aluminum: Alloy 5052 H-32 mill finish

C) Stainless Steel: 2B finish - 316L (light, cold rolled) — 2D finish - 304 (cold rolled)

Fabrication service: On large jobs, we estimate, quote, detail, and fabricate to your requirements. Lump-sum quotations are made from submitted plans and specifications. After receipt of order, a bill of materials and necessary layout drawings are prepared. Grating is supplied with special cutting, banding and toe plates installed where needed. Stair treads are also available fabricated and non-serrated. This fabrication service is available through GRIP STRUT safety grating distributors.

Installation Recommendations

General Installation Recommendations

Recommended Clearance

Steel: $\frac{1}{4}$ " minimum is recommended at perimeter and $\frac{3}{8}$ " maximum at end joints. Maximum between panels is $\frac{1}{4}$ "; $\frac{1}{8}$ " is generally used.

Concrete: Concrete form deflection calls for slightly greater perimeter clearance. $\frac{1}{2}$ " is recommended. (Maximum between panels is $\frac{1}{4}$ ").

Bearing Surfaces

Recommended minimum bearing $1\frac{1}{2}$ ". Surfaces supporting GRIP STRUT™ safety grating must be smooth and level to insure that adjoining sections provide a safe, even walking surface.

Permanent Installation

GRIP STRUT™ safety grating is easily welded to supports for permanent installations. Channels are quickly welded together between supports to provide uniform deflection in adjacent panels.

For welded-attachment, secure side channels to supports by fusion welding with $\frac{1}{8}$ " fillet welds, 1" long. Weld adjacent planks together with $\frac{1}{8}$ " fillet welds, 1" long, 24" on center staggered top and bottom.

Install GRIP STRUT safety grating according to details as shown on individual job drawings, or as follows:

- (1) Single width applications. Utilizing the anchoring device or weldings, attach GRIP STRUT safety grating plank at every point of contact with supporting structure around perimeter of plank.
- (2) Multiple width applications. Utilizing the GRIP STRUT safety grating anchoring device or welded as recommended by A.I.S.I., attach grating plank around the perimeter at each point of contact with supporting structure. In field of platform, attach plank to supporting structure with a minimum of one attachment at each end of plank on alternate sides.

When span exceeds 8 feet, weld or bolt side channels of adjacent planks together at midpoint of span. (When spans exceed 6 feet, consider similar treatment.)

MARCO

SPECIALTY STEEL

Marco Specialty Steel, Inc.
9140 Tavenor Lane
Houston, Texas 77075

Phone: 713-649-5310,
800-200-3047
Fax: 713-649-5305

www.marcospecialtysteel.com